

National Grid Electricity Distribution

(South Wales) plc

Use of System Charging Statement

NOTICE OF CHARGES

Effective from 1st April 2027

Version 0.1

This statement is in a form to be approved by the Gas and Electricity Markets Authority.

Version Control

Version	Date	Description of version and any changes made
0.1	December 2025	Published Finals

Contents

1. Introduction	4
Validity period	5
Contact details	5
2. Charge application and definitions	7
The Supercustomer / Aggregate and site-specific billing approaches	7
Supercustomer / Aggregate billing and payment	8
Site-specific billing and payment	9
Components of Charges	10
Allocation of charges	15
Generation charges for pre-2005 designated EHV properties	16
Provision of billing data	17
Out of area use of system charges	17
Licensed distribution network operator charges	17
Licence exempt distribution networks	18
3. Schedule of charges for use of the distribution system	21
4. Schedule of line loss factors	22
Role of line loss factors in the supply of electricity	22
Calculation of line loss factors	22
Publication of line loss factors	23
5. Notes for Designated EHV Properties	24
EDCM LRIC costs	24
Charges for new Designated EHV Properties	24
Charges for amended Designated EHV Properties	24
Demand-side management	24
6. Electricity distribution rebates	26
7. Accounting and administration services	26
8. Charges for electrical plant provided ancillary to the grant of use of system	26
9. Schedule of fixed adders to recover Supplier of Last Resort and Eligible Bad Debt pass-through costs	26
10. Charges for Non-Final Demand Sites	28
11. Back-up Connections	29
Appendix 1 - Glossary	31
Appendix 2 - Guidance notes	40
Background	40
Meter point administration	40
Your charges	42
Reducing your charges	42
Reactive power and reactive power charges	43
Site-specific EDCM charges	43
Appendix 3 – Non-Final Demand Site Certificate	46
Annex 1 - Schedule of charges for use of the distribution system by LV and HV Designated Properties, and Unmetered Supplies	47
Annex 2 - Schedule of charges for use of the distribution system by Designated EHV Properties (including LDNOs with Designated EHV Properties/end-users)	48
Annex 3 - Schedule of charges for use of the distribution system by preserved/additional LLF classes	66
Annex 4 - Charges applied to LDNOs with LV and HV end-users	67
Annex 5 - Schedule of line loss factors	71
Annex 6 - Charges for New or Amended Designated EHV Properties	72
Annex 7 - Final Supplier of Last Resort and Bad Debt Pass-through Costs	73

1. Introduction

- 1.1. This statement tells you about our charges and the reasons behind them. It has been prepared consistent with Standard Licence Condition 14 of our Electricity Distribution Licence. The main purpose of this statement is to provide our schedule of charges¹ for the use of our Distribution System and to provide the schedule of Line Loss Factors² that should be applied in Settlement to account for losses from the Distribution System. We have also included guidance notes in Appendix 2 to help improve your understanding of the charges we apply.
- 1.2. Within this statement we use terms such as ‘Users’ and ‘Customers’ as well as other terms which are identified with initial capitalisation. These terms are defined in the glossary.
- 1.3. This statement reflects the changes which have been introduced as a result of Market Wide Half Hourly Settlement (MHHS³). Although the existing arrangements will continue to apply for Non-Migrated MPANs, the MHHS arrangements will be effective for any MPAN that has Migrated, any differences in treatment are highlighted throughout the document.
- 1.4. The charges in this statement are calculated using the following methodologies as per the Distribution Connection and Use of System Agreement (DCUSA)⁴:
- Common Distribution Charging Methodology (CDCM); for Low Voltage (LV) and High Voltage (HV) Designated Properties as per DCUSA Schedule 16;
 - Extra High Voltage (EHV) Distribution Charging Methodology (EDCM); for Designated EHV Properties as per DCUSA Schedule 18;
 - Price Control Disaggregation Model (PCDM); for Discount Percentages used to calculate the LDNO Use of System charges in the CDCM and EDCM as per DCUSA Schedule 29.
- 1.5. Separate charges are calculated depending on the characteristics of the connection and whether the use of the Distribution System is for demand or generation

¹ Charges can be positive or negative.

² Known as adjustment factors in the Distribution Licence and commonly referred to as Loss Adjustment Factors. The schedule of Line Loss Factors will be provided in a revised statement shortly after the Line Loss Factors for the relevant year have been successfully audited by Elexon.

³ Information relating to the Market wide HH Settlement Programme available from [Home - MHHS Programme](#)

⁴ Distribution and Connection Use of System Agreement (DCUSA) available from [DCUSA Document - DCUSA](#)

purposes. Where a generation connection is seen to support the Distribution System the charges will be negative and the Supplier will receive credits for exported energy.

- 1.6. The application of charges to premises can usually be referenced using the Line Loss Factor Class (LLFC)/DUoS Tariff ID contained in the charge tables. Further information on how to identify and calculate the charge that will apply for your premises is provided in the guidance notes in Appendix 2.
- 1.7. All charges in this statement are shown **exclusive** of VAT. Invoices will include VAT at the applicable rate.
- 1.8. The annexes that form part of this statement are also available in spreadsheet format⁵. This spreadsheet contains supplementary information used for charging purposes and a simple model to assist you to calculate charges. This spreadsheet can be downloaded from www.nationalgrid.co.uk.

Validity period

- 1.9. This charging statement is valid for services provided from the effective date stated on the front of the statement and remains valid until updated by a revised version or superseded by a statement with a later effective date.
- 1.10. When using this charging statement, care should be taken to ensure that the relevant statement or statements covering the period that is of interest are used.
- 1.11. Notice of any revision to the statement will be provided to Users of our Distribution System (with the exception of updates to Annex 6; New or Amended EHV Sites which will be published as an addendum). The latest statements can be downloaded from www.nationalgrid.co.uk.

Contact details

- 1.12. If you have any questions about this statement, please contact us at this address:

Income Team
National Grid Electricity Distribution
Avonbank, Feeder Rd, Bristol
BS2 0TB
email: nged.pricing@nationalgrid.co.uk

- 1.13. All enquiries regarding connection agreements and changes to maximum capacities should be addressed to:



Connection Policy Engineer
National Grid Electricity Distribution

Herald Way, East Midlands Airport
Castle Donington
Derby
DE74 2TU
email: nged.connections@nationalgrid.co.uk

1.14. For enquiries regarding certification of Non-Final Demand sites, please contact:

Income Team
National Grid Electricity Distribution
Avonbank, Feeder Rd, Bristol
BS2 0TB
email: nged.nonfinaldemand@nationalgrid.co.uk

1.15. For all other queries please contact our general enquiries telephone number: 0800 096 3080; lines are open 08:00 – 18:00 Monday to Friday.

1.16. You can also find us on Facebook  and .

2. Charge application and definitions

2.1. The following section details how the charges in this statement are applied and billed to Users of our Distribution System.

The Supercustomer/Aggregated and site-specific billing approaches

2.2. We utilise two billing approaches depending on the type of metering data received:

- The Supercustomer / Aggregated approach for Customers for whom we receive aggregated consumption data through Settlement; and
- The 'Site-specific' approach for Customers for whom we receive site-specific consumption data through Settlement.

2.3. We receive aggregated consumption data through Settlement for:

Non-Migrated MPANs:

- Domestic and non-domestic Customers for whom Non-Half Hourly (NHH) metering data is used in Settlement (i.e., Customers with MPANs which are registered to Measurement Class A);
- Customers which are unmetered and are not settled as pseudo Half Hourly (HH) metered (i.e., Customers with MPANs which are registered to Measurement Class B);
- Domestic Customers for whom HH metering data is used in Settlement (i.e. Customers with MPANs which are registered to Measurement Class F); and
- Non-domestic Customers for whom HH metering data is used in Settlement and which have whole current (WC) metering (i.e. Customers with MPANs which are registered to Measurement Class G).

Migrated MPANs:

All Customers who have a Connection Type that indicates a Whole Current connection, i.e. with Connection Type 'W'.

2.4. We receive site-specific consumption data through Settlement for:

Non-Migrated MPANs:

- Customers for whom HH metering data is used in Settlement and which have current transformer (CT) metering (i.e. Customers with MPANs which are registered to Measurement Class C or E); and

- Customers which are unmetered and settled as pseudo HH metered (i.e. Customers with MPANs which are registered to Measurement Class D).

Migrated MPANs:

All Customers who have a Connection Type of 'L' Low Voltage, 'H' High Voltage, 'E' Extra-High Voltage or 'U' Unmetered.

Supercustomer / Aggregated billing and payment

- 2.5. The Supercustomer / Aggregated approach makes use of aggregated data obtained from Suppliers using the 'Aggregated Distribution Use of System (DUoS) Report' data flow for Non-Migrated MPANs, and the 'LDSO report for DUoS – aggregated data' message or the 'Embedded Network report for DUoS – aggregated data' message for Migrated MPANs.
- 2.6. Invoices are calculated on a periodic basis and sent to each User for whom we transport electricity through our Distribution System. Invoices are reconciled over a period of approximately 14 months to reflect later and more accurate consumption figures, this will reduce to four months following MHHS implementation).
- 2.7. The charges are applied on the basis of the LLFC/DUoS Tariff ID assigned to the MPAN, and the units consumed within the time periods specified in Annex 1. All LLFCs/DUoS Tariff IDs are assigned at our sole discretion, based on the tariff application rules set out in the appropriate charging methodology or elsewhere in this statement. Please refer to the section "Allocation of Charges' if you believe the allocated LLFC/DUoS Tariff ID or tariff is incorrect.

Supercustomer / Aggregated charges

- 2.8. Supercustomer / Aggregated charges include the following components:
- a fixed charge, pence/MPAN/day, there will only be one fixed charge applied to each MPAN; and
 - unit charges, pence/kilowatt-hour (kWh); three unit charges will apply depending on the time of day and the type of tariff for which the MPAN is registered.
- 2.9. Users who wish to supply electricity to Customers for whom we receive aggregated data through Settlement (see paragraph 2.3) will be allocated the relevant charge structure set out in Annex 1.
- 2.10. Identification of the appropriate charge can be made by cross-reference to the LLFC/DUoS Tariff ID.

- 2.11. For Non-Migrated MPANs the Valid Settlement Profile Class (PC)/Standard Settlement Configuration (SSC)/Meter Timeswitch Code (MTC) combinations for LLFC where the Metering System is Measurement Class A or B are detailed in Market Domain Data (MDD). For Migrated MPANs the appropriate reference data is contained in Industry Standing Data (ISD).
- 2.12. We do not apply a default tariff for invalid combinations.
- 2.13. The 'Domestic Aggregated (related MPAN)' and 'Non-Domestic Aggregated (related MPAN)' charges are supplementary to their respective primary MPAN charge.

Site-specific billing and payment

- 2.14. The site-specific billing and payment approach makes use of HH metering data at premises level received through Settlement.
- 2.15. Invoices are calculated on a periodic basis and sent to each User for whom we transport electricity through our Distribution System. Where an account is based on estimated data, the account shall be subject to any adjustment that may be necessary following the receipt of actual data from the User.
- 2.16. The charges are applied on the basis of the LLFC/DUoS Tariff ID assigned to the MPAN (or the (MSID) for Central Volume Allocation (CVA) sites), and the units consumed within the time periods specified in this statement.
- 2.17. All LLFCs/DUoS Tariff IDs are assigned at our sole discretion, based on the tariff application rules set out in the appropriate charging methodology or elsewhere in this statement. Please refer to the section 'Allocation of Charges' if you believe the allocated LLFC/DUoS Tariff ID or tariff is incorrect. Where an incorrectly applied LLFC/DUoS Tariff ID is identified, we may at our sole discretion apply the correct LLFC/DUoS Tariff ID and/or charges.

Site-specific billed charges

- 2.18. Site-specific billed charges for LV and HV Designated Properties may include the following components:
- a fixed charge, pence/MPAN/day or pence/MSID/day;
 - a capacity charge, pence/kilovolt-ampere (kVA)/day, for Maximum Import Capacity (MIC) and/or Maximum Export Capacity (MEC);
 - an excess capacity charge, pence/kVA/day, if a site exceeds its MIC and/or MEC;

- three unit charges, pence/kWh, depending on the time of day and the type of tariff for which the MPAN is registered; and
 - a reactive power charge, pence/kilovolt-ampere reactive hour (kVArh), for each unit in excess of the reactive charge threshold.
- 2.19. Site-specific billed charges for properties that are under transitional protection arrangements for BSC Modification P432 or MHHS will include only fixed and unit charges, in the same manner as Supercustomer / Aggregate charges, as described in 2.8.
- 2.20. Users who wish to supply electricity to Customers for whom we receive site-specific data through Settlement (see paragraph 2.4) will be allocated the relevant charge structure dependent upon the voltage and location of the Metering Point.
- 2.21. Fixed charges are generally levied on a pence per MPAN/MSID per day basis. Where two or more HH MPANs/MSIDs are located at the same point of connection (as identified in the Connection Agreement), with the same LLFC/DUoS Tariff ID, and registered to the same Supplier, only one daily fixed charge will be applied.
- 2.22. LV and HV Designated Properties will be charged in accordance with the CDCM and allocated the relevant charge structure set out in Annex 1.
- 2.23. Designated EHV Properties will be charged in accordance with the EDCM and allocated the relevant charge structure set out in Annex 2.
- 2.24. Where LV and HV Designated Properties or Designated EHV Properties have more than one point of connection (as identified in the Connection Agreement) then separate charges will be applied to each point of connection.

Components of Charges

Application of Residual Charges

- 2.25. The following sections explain the application of residual charges.

Final Demand Sites

- 2.26. Residual charges are recovered through fixed charges for all Final Demand Sites. All Non-Final Demand Sites must submit a valid certificate, as described in Section 10, and upon receipt of a valid certificate will be allocated to the relevant No Residual tariff.
- 2.27. All Back-up Connections must provide clear supporting documentary evidence to the reasonable satisfaction of the LDNO, as described in Section 11, and upon receipt of sufficient evidence will be allocated to the relevant No Residual tariff.

Residual Charging Bands

- 2.28. Residual charges are applied to Final Demand Sites on a banded basis, with all sites in a given charge band receiving the same residual charge. Domestic customers have a single charging band.
- 2.29. There are four non-domestic charging bands for each of the following groups:
- Designated Properties connected at LV, billing with no MIC;
 - Designated Properties connected at LV, billing with MIC;
 - Designated Properties connected at HV; and
 - Designated EHV Properties.
- 2.30. All non-domestic Final Demand customers are allocated into one of the four charging bands, for each relevant charge structure.
- 2.31. The residual charging band boundaries are calculated nationally based upon data from all LDNOs. The method and timing for calculating the residual charging band boundaries and the method and timing for allocating customers into the residual charging bands are set out in Schedule 32 of DCUSA.
- 2.32. The boundaries for the residual bands can be found in the 'Schedule of charges and other tables' spreadsheet on our website, as well as the mapping between the DUoS Tariff name and TNUOS site charging band.

Time periods

- 2.33. The time periods for the application of unit charges to metered LV and HV Designated Properties are detailed in Annex 1. We have not issued a notice to change the time bands.
- 2.34. The time periods for the application of unit charges to Unmetered Supply Exit Points are detailed in Annex 1. We have not issued a notice to change the time bands.
- 2.35. The time periods for the application of unit charges to Designated EHV Properties are detailed in Annex 2. We have not issued a notice to change the time bands.

Application of capacity charges

- 2.36. The following sections explain the application of capacity charges and exceeded capacity charges.

Chargeable capacity

- 2.37. The chargeable capacity is, for each billing period, the MIC/MEC, as detailed below.
- 2.38. The MIC/MEC will be agreed with us at the time of connection or pursuant to a later change in requirements. Following such an agreement (be it at the time of connection or later) no reduction in MIC/MEC will be allowed for a 12 month period.
- 2.39. Reductions to the MIC/MEC may only be permitted once in a 12 month period. Where the MIC/MEC is reduced the new lower level will be agreed with reference to the level of the Customer's maximum import and/or export demand respectively. The new MIC/MEC will be applied from the start of the next billing period after the date that the request was received. It should be noted that, where a new lower level is agreed, the original capacity may not be available in the future without the need for network reinforcement and associated charges.
- 2.40. In the absence of an agreement, the chargeable capacity, save for error or omission, will be based on the last MIC/MEC that we have previously agreed for the relevant premises' connection. A Customer can seek to agree or vary the MIC/MEC by contacting us using the contact details in section 1.12.

Exceeded capacity

- 2.41. Where a customer takes additional unauthorised capacity over and above the MIC/MEC, the excess will be classed as exceeded capacity. The exceeded portion of the capacity will be charged at the excess capacity charge p/kVA/day rate, based on the difference between the MIC/MEC and the actual capacity used. This will be charged for the full duration of the billing period in which the breach occurs.

Demand exceeded capacity

$$\text{Demand exceeded capacity} = \max(2 \times \sqrt{AI^2 + \max(RI, RE)^2} - MIC, 0)$$

Where:

AI = Active import (kWh)

RI = Reactive import (kVArh)

RE = Reactive export (kVArh)

MIC = Maximum import capacity (kVA)

- 2.42. Only reactive import and reactive export values occurring at times of active import are used in the calculation. Where data for two or more MPANs is aggregated for billing purposes the HH consumption values are summated prior to the calculation above.

2.43. This calculation is completed for every half hour and the maximum value from the billing period is applied.

Generation exceeded capacity

$$\text{Generationexceededcapacity} = \max(2 \times \sqrt{AE^2 + \max(RI, RE)^2} - MEC, 0)$$

Where:

AE = Active export (kWh)

RI = Reactive import (kVArh)

RE = Reactive export (kVArh)

MEC = Maximum export capacity (kVA)

2.44. Only reactive import and reactive export values occurring at times of active export are used in the calculation. Where data for two or more MPANs is aggregated for billing purposes the HH consumption values occurring at times of kWh export are summated prior to the calculation above.

2.45. This calculation is completed for every half hour and the maximum value from the billing period is applied.

Standby capacity for additional security on site

2.46. Where standby capacity charges are applied, the charge will be set at the same rate as that applied to normal MIC. Should a customer's request for additional security of supply require the provision of capacity from two different sources, we reserve the right to charge for the capacity held at each source.

Minimum capacity levels

2.47. There is no minimum capacity threshold.

Application of charges for excess reactive power

2.48. When an individual HH metered MPAN's reactive power (measured in kVArh) at LV and HV Designated Properties exceeds 33% of its total active power (measured in kWh) in any given half hour, excess reactive power charges will apply. This threshold is equivalent to an average power factor of 0.95 during that half hour. Any reactive units in excess of the 33% threshold are charged at the rate appropriate to the particular charge.

2.49. Power Factor is calculated as follows:

$$\text{Cos } \theta = \text{Power Factor}$$

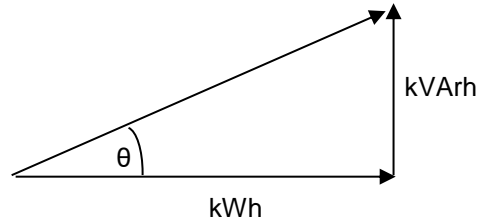

2.50. The chargeable reactive power is calculated as follows:

Demand chargeable reactive power

$$\text{Demand chargeable kVArh} = \max\left(\max(RI, RE) - \left(\sqrt{\left(\frac{1}{0.95^2} - 1\right)} \times AI\right), 0\right)$$

Where:

AI = Active import (kWh)

RI = Reactive import (kVArh)

RE = Reactive export (kVArh)

2.51. Only reactive import and reactive export values occurring at times of active import are used in the calculation. Where data for two or more MPANs is aggregated for billing purposes the HH consumption values are summated prior to the calculation above.

2.52. The square root calculation will be to two decimal places.

2.53. This calculation is completed for every half hour and the values summated over the billing period.

Generation chargeable reactive power

$$\text{Generation chargeable kVArh} = \max\left(\max(RI, RE) - \left(\sqrt{\left(\frac{1}{0.95^2} - 1\right)} \times AE\right), 0\right)$$

Where:

AE = Active export (kWh)

RI = Reactive import (kVArh)

RE = Reactive export (kVArh)

2.54. Only reactive import and reactive export values occurring at times of active export are used in the calculation. Where data for two or more MPANs is aggregated for

billing purposes the HH consumption values are summated prior to the calculation above.

2.55. The square root calculation will be to two decimal places.

2.56. This calculation is completed for every half hour and the values summated over the billing period.

Allocation of charges

2.57. It is our responsibility to apply the correct charges to each MPAN/MSID. The allocation of charges is based on the voltage of connection, import/export details including multiple MPANs, metering information and, for some tariffs, the metering location.

2.58. We are responsible for deciding the voltage of connection. Generally, this is determined by where the metering is located and where responsibility for the electrical equipment transfers from us to the connected Customer.

2.59. We are also responsible for allocating non-domestic customers into their residual charging bands. Allocation into residual charging bands is determined by consumption for customers billed under the Supercustomer / Aggregated approach and for properties that are under transitional protection arrangements for BSC Modification P432 or MHHS, and by the MIC for all other customers billed under the site-specific approach.

2.60. The Supplier determines and provides us with the metering information and data to enable us to allocate charges. The metering information and data is likely to change over time if, for example, a Supplier changes an MPAN from non-domestic to domestic following a change of use at the premise. When we are notified, this has happened we will change the allocation of charges accordingly.

2.61. If it has been identified that a charge may have been incorrectly allocated due to the metering information and/or data then a request for investigation should be made to the Supplier.

2.62. Where it has been identified that a charge is likely to be incorrectly allocated due to the voltage of connection; import/export details; metering location; or allocation to residual charging band then a request to investigate the applicable charges should be made to us. Requests from persons other than the Customer or the current Supplier must be accompanied by a Letter of Authority from the Customer; the current Supplier must also acknowledge that they are aware a request has been made. Any request must be supported by an explanation of why it is believed that

the current charge should be changed, along with supporting information including, where appropriate, photographs of metering positions or system diagrams. Any request to change the current charge that also includes a request for backdating must include justification as to why it is considered appropriate to backdate the change.

- 2.63. Where a residual charging band allocation cannot be resolved, the dispute process provided within DCUSA Schedule 32 should be followed.
- 2.64. An administration charge (covering our reasonable costs) may be made if a technical assessment or site visit is required, but we will not apply any charge where we agree to the change request.
- 2.65. Where we agree that the current LLFC/DUoS Tariff ID charge should be changed, we will then allocate the appropriate set of charges for the connection. Any adjustment will be applied from the date of the request, back to either the date of the incorrect allocation, or up to the maximum period specified by the Limitation Act (1980) in England and Wales, which covers a six-year period from the date of request; whichever is the shorter.
- 2.66. Any credit or additional charge will be issued to the relevant Supplier(s) effective during the period of the change.
- 2.67. Should we reject the request (as per paragraph 2.62) a justification will be provided to the requesting party. We shall not unreasonably withhold or delay any decision on a request to change the charges applied and would expect to confirm our position on the request within three months of the date of request.

Generation charges for pre-2005 designated EHV properties

- 2.68. Designated EHV Properties that were connected to the Distribution System under a pre-2005 connection charging policy are eligible for exemption from Use of System (UoS) charges for generation unless one of the following criteria has been met:
 - 25 years have passed since their first energisation/connection date (i.e. Designated EHV Properties with Connection Agreements dated prior to 1st April 2005, and for which 25 years has passed since their first energisation/connection date will receive UoS charges for generation from the next charging year following the expiry of their 25 years exemption, (starting 1st April), or
 - the person responsible for the Designated EHV Property has provided notice to us that they wish to opt in to UoS charges for generation.

If a notice to opt in has been provided there will be no further opportunity to opt out.

- 2.69. Furthermore, if an exempt Customer makes an alteration to its export requirement, then the Customer may be liable to be charged for the additional capacity required for energy imported or exported. For example, where a generator increases its export capacity the incremental increase in export capacity will attract UoS charges as with other non-exempt generators.

Provision of billing data

- 2.70. Where HH metering data is required for UoS charging and this is not provided in accordance with the BSC or DCUSA, such metering data shall be provided to us by the User of the system in respect of each calendar month within five working days of the end of that calendar month.
- 2.71. The metering data shall identify the amount of energy conveyed across the Metering System in each half hour of each day and shall separately identify active and reactive import and export. Metering data provided to us shall be consistent with that received through the metering equipment installed.
- 2.72. Metering data shall be provided in an electronic format specified by us from time to time and, in the absence of such specification, metering data shall be provided in a comma-separated text file in the format of data flow D0036⁶ for Non-Migrated MPANs, and the REP-900 message for Migrated MPANs (as agreed with us). The data shall be emailed to nged.duos@nationalgrid.co.uk.
- 2.73. We require details of reactive power imported or exported to be provided for all Measurement Class C and E sites for Non-Migrated MPANs, and for all Migrated MPANs with a Connection Type of 'L', 'H' or 'E'. It is also required for CVA sites and Exempt Distribution Network boundaries with difference metering. We reserve the right to levy a charge on Users who fail to provide such reactive data. In order to estimate missing reactive data, a power factor of 0.9 lag will be applied to the active consumption in any half hour.

Out of area use of system charges

- 2.74. We do not operate networks outside our Distribution Services Area.

Licensed distribution network operator charges

- 2.75. Licensed Distribution Network Operator (LDNO) charges are applied to LDNOs who operate Embedded Networks within our Distribution Services Area.

⁶ Data Transfer Catalogue available from <https://www.electralink.co.uk/dtc-catalogue>

- 2.76. The charge structure for LV and HV Designated Properties embedded in networks operated by LDNOs will mirror the structure of the 'All-the-way' charge and is dependent upon the voltage of connection of each embedded network to our Distribution System. The relevant charge structures are set out in Annex 4.
- 2.77. We do not apply a default tariff for invalid combinations.
- 2.78. The charge structure for Designated EHV Properties embedded in networks operated by LDNOs will be calculated individually using the EDCM. The relevant charge structures are set out in Annex 2.
- 2.79. For Nested Networks the relevant charging principles set out in DCUSA Schedule 21 will apply.

Licence exempt distribution networks

- 2.80. The Electricity and Gas (Internal Market) Regulations 2011⁷ introduced obligations on owners of licence exempt distribution networks (sometimes called private networks) including a duty to facilitate access to electricity and gas suppliers for Customers within those networks.
- 2.81. When Customers (both domestic and commercial) are located within a licence exempt distribution network and require the ability to choose their own Supplier this is called 'third party access'. These embedded Customers will require an MPAN so that they can have their electricity supplied by a Supplier of their choice.
- 2.82. Licence exempt distribution networks owners can provide third party access using either full settlement metering or the difference metering approach⁸.

Full settlement metering

- 2.83. This is where a licence exempt distribution network is set up so that each embedded installation has an MPAN and Metering System and therefore all Customers purchase electricity from their chosen Supplier. In this case there are no Settlement Metering Systems at the boundary between the licensed Distribution System and the licence exempt distribution network.
- 2.84. In this approach our UoS charges will be applied to each MPAN.

⁷ The Electricity and Gas (Internal Market) Regulations 2011 available from <http://www.legislation.gov.uk/uksi/2011/2704/contents/made>

⁸ Elexon's guide is available from <https://bscdocs.elexon.co.uk/guidance-notes/third-party-access-to-licence-exempt-distribution-networks>

Difference metering

2.85. This is where one or more, but not all, Customers on a licence exempt distribution network choose their own Supplier for electricity supply to their premises. Under this approach, the Customers requiring third party access on the licence exempt distribution network will have their own MPAN and must have a HH Metering System.

Shared Metering

2.86. This is where one or more Customers on a licence exempt distribution network choose their own Supplier for electricity supply to their premises, and the active import and/or active export meter readings at the boundary are apportioned between the Suppliers. Under this approach, the Customers requiring third party access on the licence exempt distribution network will have their own MPAN and must have a HH Metering System.

2.87. In this approach our UoS charges will be applied to each MPAN.

Gross settlement

2.88. Where one of our MPANs (Prefix 21) is embedded within a licence exempt distribution network connected to our Distribution System, and difference metering is in place for Settlement purposes and we receive gross measurement data for the boundary MPAN, we will continue to charge the boundary MPAN Supplier for use of our Distribution System. No charges will be levied by us directly to the Customer or Supplier of the embedded MPAN(s) connected within the licence exempt distribution network.

2.89. We require that gross metered data for the boundary of the connection is provided to us. Until a new industry data flow is introduced for the sending of such gross data, gross metered data shall:

- be provided in a text file in the format of the D0036 data flow;
- the text file shall be emailed to nged.duos@nationalgrid.co.uk;
- the title of the email should also contain the phrase “gross data for difference metered private network” and contain the metering reference specified by us in place of the Settlement MPAN; and
- the text filename shall be formed of the metering reference specified by us followed by a hyphen and followed by a timestamp in the format YYYYMMDDHHMMSS and followed by “.txt”.

2.90. For the avoidance of doubt, the reduced difference metered measurement data for the boundary connection that is to enter Settlement should continue to be sent using the Settlement MPAN.

Net settlement

2.91. Where one of our MPANs (Prefix 21) is embedded within a licence exempt distribution network connected to one of our Distribution Systems, and difference metering is in place for Settlement purposes, and we do **not** receive gross measurement data for the boundary MPAN, we will charge the boundary MPAN Supplier based on the net measurement for use of our Distribution System. Charges will also be levied directly to the Supplier of the embedded MPAN(s) connected within the licence exempt distribution network based on the actual data received.

3. Schedule of charges for use of the distribution system

- 3.1. Tables listing the charges for use of our Distribution System are published in annexes to this document.
- 3.2. These charges are also listed in a spreadsheet which is published with this statement and can be downloaded from www.nationalgrid.co.uk.
- 3.3. Annex 1 contains the charges applied to LV and HV Designated Properties.
- 3.4. Annex 2 contains the charges applied to our Designated EHV Properties and charges applied to LDNOs for Designated EHV Properties connected to their Distribution Systems.
- 3.5. Annex 3 contains details of any preserved and additional charges that are valid at this time. Preserved charges are mapped to an appropriate charge and are closed to new Customers.
- 3.6. Annex 4 contains the charges applied to LDNOs in respect of LV and HV Designated Properties connected to their Distribution Systems.

4. Schedule of line loss factors

Role of line loss factors in the supply of electricity

- 4.1. Electricity entering or exiting our Distribution System is adjusted to take account of energy that is lost⁹ as it is distributed through the network. This adjustment does not affect distribution charges but is used in energy settlement to take metered consumption to a notional Grid Supply Point so that Suppliers' purchases take account of the energy lost on the Distribution System.
- 4.2. We are responsible for calculating the Line Loss Factors (LLFs) and providing these to Elexon. Elexon is the company that manages the BSC.
- 4.3. LLFs are used to adjust the Metering System volumes to take account of losses on the Distribution System.

Calculation of line loss factors

- 4.4. LLFs are calculated in accordance with BSCP128, which sets out the procedure and principles with which our LLF methodology must comply. It also defines the procedure and timetable by which LLFs are reviewed and submitted.
- 4.5. LLFs are calculated for a set number of time periods during the year using either a generic or site-specific method. The generic method is used for sites connected at LV or HV and the site-specific method is used for sites connected at EHV or where a request for site-specific LLFs has been agreed. Generic LLFs will be applied as a default to all new EHV sites until sufficient data is available for a site-specific calculation.

Where the usage profile for a given site contains insufficiently large consumption or generation volumes to enable calculation of realistic site-specific LLFs then a default calculation, or default replacement process shall be undertaken.

A default replacement process shall be deemed to have been undertaken if a generic methodology is used where the following applies:

- (a) A Site has multiple connections to the total system and the primary connection is at EHV but there is a subordinate connection that is not connected at EHV, then a generic methodology may be used for the subordinate connection (even if a site-specific LLF is used for the Site's primary connection); and

⁹ Energy can be lost for technical and non-technical reasons and losses normally occur by heat dissipation through power flowing in conductors and transformers. Losses can also reduce if a customer's action reduces power flowing in the distribution network. This might happen when a customer generates electricity and the produced energy is consumed locally.

(b) The connection has a capacity of less than or equal to 1MVA

The definition of EHV used for LLF purposes differs from the definition used for defining Designated EHV Properties in the EDCM. The definition used for LLF purposes can be found in our LLF methodology, which can be found on the Elexon website¹⁰.

Publication of line loss factors

- 4.6. The LLFs used in Settlement are published on the Elexon Portal¹¹. The website contains the LLFs in standard industry data formats and in a summary form. A user guide with details on registering and using the portal is also available.
- 4.7. BSCP128 sets out the timetable by which LLFs are submitted and audited. The submission and audit occurs between September and December in the year prior to the LLFs becoming effective. Only after the completion of the audit at the end of December and BSC approval are the final LLFs published.
- 4.8. As this statement is published a complete year before the LLFs for the charging year have been produced, Annex 5 is intentionally left blank. This statement will be reissued with Annex 5 populated once the LLFs have been calculated and audited. This should typically be more than three months prior to the statement coming into force.
- 4.9. When using the tables in Annex 5, reference should be made to the LLFC allocated to a Non-Migrated MPAN or to the DUoS Tariff ID allocated to a Migrated MPAN to find the appropriate values.

¹⁰ BSCP128: Production, Submission, Audit and Approval of Line Loss Factors
<https://www.elexon.co.uk/csd/bscp128-production-submission-audit-and-approval-of-line-loss-factors/>

¹¹ The Elexon Portal can be accessed from www.elexonportal.co.uk

5. Notes for Designated EHV Properties

EDCM LRIC costs

- 5.1. A table is provided in the accompanying spreadsheet which shows the underlying Long Run Incremental Cost Pricing (LRIC) nodal costs used to calculate the current EDCM charges. This spreadsheet is available to download from our website www.nationalgrid.co.uk.
- 5.2. These are illustrative of the modelled costs at the time that this statement was published. A new connection will result in changes to current network utilisations, which will then form the basis of future prices. The charge determined in this statement will not necessarily be the charge in subsequent years because of the interaction between new and existing network connections and any other changes made to our Distribution System which may affect charges.

Charges for new Designated EHV Properties

- 5.3. Charges for any new Designated EHV Properties calculated after publication of the current statement will be published on our website in an addendum to that statement as and when necessary. The addendum will include charge information of the type found in Annex 2, and LLFs as found in Annex 5.
- 5.4. The form of the addendum is detailed in Annex 6 to this statement.
- 5.5. The new Designated EHV Properties' charges will be added to Annex 2 in the next full statement released.

Charges for amended Designated EHV Properties

- 5.6. Where an existing Designated EHV Property is modified and energised in the charging year, we may revise the EDCM charges for the modified Designated EHV Property. If revised charges are appropriate, an addendum will be sent to all relevant parties and published as a revised 'Schedule of Charges and other tables' spreadsheet on our website. The modified Designated EHV Property charges will be added to Annex 2 in the next full statement released.

Demand-side management

- 5.7. New or existing Designated EHV Property Customers may wish to offer part of their MIC to be interruptible by us (for active network management purposes other than normal planned or unplanned outages) in order to benefit from any reduced UoS charges calculated using the EDCM.

- 5.8. Several options exist in which we may agree for some or the entire MIC to be interruptible. Under the EDCM the applicable demand capacity costs would be based on the MIC minus the capacity subject to interruption.
- 5.9. If you are interested in making part or all of your MIC interruptible as an integral irrevocable feature of a new connection or modification to an existing connection you should in the first instance, contact our connections function;
- Online at <https://connections.nationalgrid.co.uk>
 - By email at nged.newsupplies@nationalgrid.co.uk
 - By telephone on 0800 0963080

You must make an express statement in your application that you have an interest in some or all of the import capacity being interruptible for active network management purposes.

- 5.10. If you are proactively interested in voluntarily but revocably offering to make some or all of your existing connection's MIC interruptible you should in the first instance, contact our Income Manager at the address in paragraph 1.13.
- 5.11. No adjustments are made in the EDCM for interruptible Maximum Export Capacity under Generation Side Management (GSM) agreements.
- 5.12. We also engage flexibility services from customers on a commercial basis, without adjustments in the EDCM. If you are interested in offering such services, please visit <https://www.flexiblepower.co.uk> or contact nged.flexiblepower@nationalgrid.co.uk

6. Electricity distribution rebates

- 6.1. We have neither given nor announced any DUoS rebates to Users in the 12 months preceding the date of publication of this version of the statement.

7. Accounting and administration services

- 7.1. We reserve the right to impose payment default remedies. The remedies are as set out in DCUSA where applicable or else as detailed in the following paragraph.
- 7.2. If any invoices that are not subject to a valid dispute remain unpaid on the due date, late payment interest (calculated at base rate plus 8%) and administration charges may be imposed.
- 7.3. Our administration charges are detailed in the following table. These charges are set at a level which is in line with the Late Payment of Commercial Debts Act;

Size of Unpaid Debt	Late Payment Fee
Up to £999.99	£40.00
£1,000 to £9,999.99	£70.00
£10,000 or more	£100.00

8. Charges for electrical plant provided ancillary to the grant of use of system

- 8.1. None.

9. Schedule of fixed adders to recover Supplier of Last Resort and Eligible Bad Debt pass-through costs

Supplier of Last Resort

- 9.1. In accordance with Standard Condition 38B 'Last Resort Supply Payment Claims' ('SLC38B') and Special Condition 6 'Pass-through expenditure' ('SpC6') of our Electricity Distribution Licence, our charges will recover the amount of payments in Regulatory Year t made in response to Last Resort Supply Payment claims.

Eligible Bad Debt

- 9.2. In accordance with SpC6, our charges will recover the amount of use of system bad debt the Authority has consented to be recovered. This represents use of system bad debt our charges are recovering on behalf of Independent Distribution Network

Operators (IDNOs), in accordance with Standard Licence Condition 38C 'Treatment of Valid Bad Debt Claims' ('SLC38C'), and specifically paragraph 4 of that condition.

Tables of Fixed Adders

- 9.3. Tables listing the charges to recover Supplier of Last Resort and Eligible Bad Debt pass-through costs are published in Annex 7 to this document. The charges are shown for information only and are already included in the final charges.

10. Non-Final Demand Sites

Charges for Non-Final Demand Sites

10.1. A Non-Final Demand Site is charged an import tariff that excludes the residual cost element of charges. If the User wishes for a property to qualify for allocation to these tariffs, then the User must submit certification declaring that the property meets the required criteria as per DCUSA.

Process for submitting certification

10.2. This certification should take the form as set out in Appendix 3 and be submitted to us using the contact details in 1.133.

We may, at our discretion, request a signed paper certificate from the User, in place of electronic. If requested, paper certification should be posted to the contact details in 1.13.

10.3. Users should undertake reasonable endeavours to ensure the facts attested to in the certification are true. We may request documentation evidencing these endeavours, including where appropriate, photographs of metering positions or system diagrams, following receipt of the certification.

10.4. If we determine that the documentation provided does not sufficiently evidence the undertaking of reasonable endeavours, does not support the facts attested to in the certification, or if no documentation is received, we may at our discretion reject the certification as invalid. If the certification is rejected as invalid, then the property will not qualify as a Non-Final Demand Site.

Application of charges for Non-Final Demand Sites

10.5. A property will only be deemed to qualify as a Non-Final Demand Site, and be allocated charges as such, from the date on which we receive valid certification.

10.6. If a property that has previously been certified as a Non-Final Demand Site no longer satisfies the criteria as per DCUSA, then the User must inform us immediately.

10.7. For a property that has been previously certified as a Non-Final Demand Site, we will continue to apply the relevant no residual import tariff without the requirement for further certification, except in any one of the following circumstances:

- Where we have reason to believe that the property no longer qualifies as a Non-Final Demand Site; or
- Significant time has passed since the certification was submitted; or
- Where there is a change to the connection characteristics i.e. capacity change.

If such circumstances occur, we may request re-certification of the site, or reject the certification as invalid at our discretion.

10.8. When a property no longer meets the required criteria to qualify as a Non-Final Demand Site, we will change the allocation of charges accordingly from that point.

10.9. Please refer to the section 'Incorrectly allocated charges' if you believe the property has been incorrectly not allocated charges as a Non-Final Demand Site.

11. Back-up Connections

Charges for Back-up Connections

11.1. A Back-up Connection is charged an import tariff that excludes the residual cost element of charges. If the User wishes for a MPAN/MSID to qualify for allocation to these tariffs, then the User must provide evidence necessary to satisfy the definition of Back-up Connection as per DCUSA.

Process for providing evidence

11.2. Users should undertake reasonable endeavours to ensure the facts attested to in the request are true. We may request documentation evidencing these endeavours, including where appropriate, photographs of metering positions or system diagrams.

11.3. If we determine that the documentation provided does not sufficiently evidence the undertaking of reasonable endeavours, does not support the facts attested to in the request, or if no documentation is received, we may at our discretion reject the evidence as invalid. If the evidence is rejected as invalid, then the property will not qualify as a Back-up Connection.

Application of charges for Back-up Connections

11.4. A MPAN/MSID will only be deemed to qualify as a Back-up Connection, and be allocated charges as such, from the first of the month following the date on which we receive valid evidence.

11.5. If a MPAN/MSID that has previously been appointed as a Back-up Connection no longer satisfies the criteria as per DCUSA, then the User must inform us immediately.

11.6. For a MPAN/MSID that has been previously certified as a Back-up Connection, we will continue to apply the relevant no residual import tariff without the requirement for further certification, except in any one of the following circumstances:

- Where we have reason to believe that the MPAN/MSID no longer qualifies as a Back-up Connection; or

- Significant time has passed since the evidence was submitted; or
- Where there is a change to the connection characteristics i.e. capacity change.

If such circumstances occur, we may request evidence to be provided again for the site, or reject the evidence as invalid at our discretion.

11.7. When a MPAN/MSID no longer meets the required criteria to qualify as a Back-up Connection, we will change the allocation of charges accordingly from that point.

11.8. Please refer to the section 'Incorrectly allocated charges' if you believe the MPAN/MSID has been incorrectly not allocated charges as a Back-up Connection.

Appendix 1 - Glossary

1.1. The following definitions, which can extend to grammatical variations and cognate expressions, are included to aid understanding:

Term	Definition
All-the-way Charge	A charge that is applicable to an end user rather than an LDNO. An end user in this context is a Supplier/User who has a registered MPAN or MSID and is using the Distribution System to transport energy on behalf of a Customer.
Back-up Connection	As defined in DCUSA Schedule 32.
Balancing and Settlement Code (BSC)	The BSC contains the governance arrangements for electricity balancing and settlement in Great Britain. An overview document is available from www.elexon.co.uk/ELEXON Documents/trading_arrangements.pdf .
Balancing and Settlement Code Procedure (BSCP)	A document of that title, as established or adopted and from time to time modified by the Panel in accordance with The Code, setting out procedures to be complied with (by Parties, Party Agents, BSC Agents, BSCCo, the Panel and others) in, and other matters relating to, the implementation of The Code;
Common Distribution Charging Methodology (CDCM)	The CDCM used for calculating charges to Designated Properties as required by standard licence condition 13A of the Electricity Distribution Licence.
Connection Agreement	An agreement between an LDNO and a Customer which provides that that Customer has the right for its connected installation to be and remain directly or indirectly connected to that LDNO's Distribution System
Central Volume Allocation (CVA)	As defined in the BSC.
Connection Type	Defines the physical connection as one of four valid types for metered supplies: 'W' Whole Current; 'L' Low Voltage (LV) Current Transformer; 'H' High Voltage (HV) Current Transformer; or 'E' Extra High Voltage (EHV) Current Transformer (E). It will also include a value of 'U' for unmetered connections.

Term	Definition
Customer	<p>A person to whom a User proposes to supply, or for the time being supplies, electricity through an exit point, or from who, a User or any relevant exempt supplier, is entitled to recover charges, compensation or an account of profits in respect of electricity supplied through an exit point;</p> <p>Or</p> <p>A person from whom a User purchases, or proposes to purchase, electricity, at an entry point (who may from time to time be supplied with electricity as a Customer of that User (or another electricity supplier) through an exit point).</p>
Designated EHV Properties	As defined in standard condition 13B of the Electricity Distribution Licence.
Designated Properties	As defined in standard condition 13A of the Electricity Distribution Licence.
Distribution Connection and Use of System Agreement (DCUSA)	<p>The DCUSA is a multi-party contract between the licensed electricity distributors, suppliers, generators and Offshore Transmission Owners of Great Britain.</p> <p>It is a requirement that all licensed electricity distributors and suppliers become parties to the DCUSA.</p>

Distributor IDs	These are unique IDs that can be used, with reference to the MPAN, to identify your LDNO. The charges for other network operators can be found on their website.		
	ID	Distribution Service Area	Company
	10	East of England	UK Power Networks
	11	East Midlands	National Grid Electricity
	12	London	UK Power Networks
	13	Merseyside and North Wales	Scottish Power
	14	Midlands	National Grid Electricity
	15	Northern	Northern Powergrid
	16	North Western	Electricity North West
	17	Scottish Hydro Electric (and embedded networks in other areas)	Scottish Hydro Electric Power Distribution plc
	18	South Scotland	Scottish Power
	19	South East England	UK Power Networks
	20	Southern Electric (and embedded networks in other areas)	Southern Electric Power Distribution plc
	21	South Wales	National Grid Electricity
	22	South Western	National Grid Electricity
	23	Yorkshire	Northern Powergrid
	24	All	Independent Power Networks
	25	All	ESP Electricity
	26	All	Energetics Electricity Ltd
	27	All	The Electricity Network Company Ltd
	29	All	Harlaxton Energy Networks
	30	All	Peel Electricity Networks Ltd
	31	All	UK Power Distribution Ltd
	32	All	Energy Assets Networks Limited
	33	All	Eclipse Power Networks Ltd
	34	All	Murphy Power Distribution Ltd
	35	All	Fulcrum Electricity Assets Ltd
	36	All	Vattenfall Networks Ltd
	37	All	Forbury Assets Limited
	38	All	Indigo Power Limited
	39	All	Stark Infra-Electricity Ltd

Term	Definition																								
	<table border="1"> <tr> <td data-bbox="619 241 692 282">40</td> <td data-bbox="692 241 1038 282">All</td> <td data-bbox="1038 241 1369 282">Utility Assets Limited</td> </tr> <tr> <td data-bbox="619 282 692 385">42</td> <td data-bbox="692 282 1038 385">All</td> <td data-bbox="1038 282 1369 385">Advanced Electricity Networks</td> </tr> <tr> <td data-bbox="619 385 692 425">43</td> <td data-bbox="692 385 1038 425">All</td> <td data-bbox="1038 385 1369 425">IDCSL</td> </tr> <tr> <td data-bbox="619 425 692 465">45</td> <td data-bbox="692 425 1038 465">All</td> <td data-bbox="1038 425 1369 465">Aurora Utilities Limited</td> </tr> <tr> <td data-bbox="619 465 692 506">46</td> <td data-bbox="692 465 1038 506">All</td> <td data-bbox="1038 465 1369 506">Aidien Limited</td> </tr> <tr> <td data-bbox="619 506 692 586">47</td> <td data-bbox="692 506 1038 586">All</td> <td data-bbox="1038 506 1369 586">Vital Energi Power Networks</td> </tr> <tr> <td data-bbox="619 586 692 667">48</td> <td data-bbox="692 586 1038 667">All</td> <td data-bbox="1038 586 1369 667">E.ON UK Network Assets Limited</td> </tr> <tr> <td data-bbox="619 667 692 703">51</td> <td data-bbox="692 667 1038 703">All</td> <td data-bbox="1038 667 1369 703">AGR Networks Ltd</td> </tr> </table>	40	All	Utility Assets Limited	42	All	Advanced Electricity Networks	43	All	IDCSL	45	All	Aurora Utilities Limited	46	All	Aidien Limited	47	All	Vital Energi Power Networks	48	All	E.ON UK Network Assets Limited	51	All	AGR Networks Ltd
40	All	Utility Assets Limited																							
42	All	Advanced Electricity Networks																							
43	All	IDCSL																							
45	All	Aurora Utilities Limited																							
46	All	Aidien Limited																							
47	All	Vital Energi Power Networks																							
48	All	E.ON UK Network Assets Limited																							
51	All	AGR Networks Ltd																							
Distribution Network Operator (DNO)	An electricity distributor that operates one of the 14 distribution services areas and in whose Electricity Distribution Licence the requirements of Section B of the standard conditions of that licence have effect.																								
Distribution Services Area	The area specified by the Gas and Electricity Markets Authority within which each DNO must provide specified distribution services.																								
Distribution System	<p>The system consisting (wholly or mainly) of electric lines owned or operated by an authorised distributor that is used for the distribution of electricity from:</p> <ul style="list-style-type: none"> • Grid Supply Points or generation sets or other entry points <p>to the points of delivery to:</p> <ul style="list-style-type: none"> • Customers or Users or any transmission licensee in its capacity as operator of that licensee's transmission system or the Great Britain (GB) transmission system and includes any remote transmission assets (owned by a transmission licensee within England and Wales) that are operated by that authorised distributor and any electrical plant, electricity meters, and metering equipment owned or operated by it in connection with the distribution of electricity, but does not include any part of the GB transmission system. 																								
DUoS Tariff Id	An identifier assigned to an SVA metering system which is used to assign the use of system charges for Migrated MPANs																								
EHV Distribution Charging Methodology (EDCM)	The EDCM used for calculating charges to Designated EHV Properties as required by standard licence condition 13B of the Electricity Distribution Licence.																								
Electricity Distribution Licence	The Electricity Distribution Licence granted or treated as granted pursuant to section 6(1) of the Electricity Act 1989.																								
Electricity Distributor	Any person who is authorised by an Electricity Distribution Licence to distribute electricity.																								

Term	Definition
Embedded Network	An electricity Distribution System operated by an LDNO and embedded within another Distribution System.
Embedded Network report for DUoS – aggregated data	A report of data by IDNO’s DUoS Tariff ID and by IDNO providing counts of MPANs and units consumed
Engineering Recommendation P2/6	A document of the Energy Networks Association, which defines planning standards for security of supply and is referred to in Standard Licence Condition 24 of the Electricity Distribution Licence.
Entry Point	A boundary point at which electricity is exported onto a Distribution System from a connected installation or from another Distribution System, not forming part of the total system (boundary point and total system having the meaning given to those terms in the BSC).
Exit Point	A point of connection at which a supply of electricity may flow from the Distribution System to the Customer’s installation or User’s installation or the Distribution System of another person.
Extra High Voltage (EHV)	Nominal voltages of 22kV and above.
Final Demand Site	As defined in DCUSA Schedule 32.
Gas and Electricity Markets Authority (GEMA)	As established by the Utilities Act 2000.
Grid Supply Point (GSP)	A metered connection between the National Grid Electricity Transmission system and the licensee’s distribution system at which electricity flows to or from the Distribution System.
GSP group	A distinct electrical system that is supplied from one or more GSPs for which total supply into the GSP group can be determined for each half hour.
High Voltage (HV)	Nominal voltages of at least 1kV and less than 22kV.
Industry Standing Data (ISD)	Industry Standing Data (ISD) is the reference data used in Settlement processes under MHHS.
Invalid Settlement Combination	A Settlement combination that is not recognised as a valid combination in market domain data - see https://www.elexonportal.co.uk/MDDVIEWER .
kVA	Kilovolt ampere.
kVArh	Kilovolt ampere reactive hour.
kW	Kilowatt.
kWh	Kilowatt hour (equivalent to one “unit” of electricity).
LDSO report for DUoS – aggregated data	A report of data by DUoS Tariff ID and Supplier providing counts of MPANs and units consumed

Term	Definition
Licensed Distribution Network Operator (LDNO)	The holder of a Licence to distribute electricity.
Line Loss Factor (LLF)	The factor that is used in Settlement to adjust the metering system volumes to take account of losses on the distribution system.
Line Loss Factor Class (LLFC)	An identifier assigned to an SVA metering system which is used to assign the LLF and use of system charges for Non-Migrated MPANs.
Load Factor	$= \frac{\text{annual consumption (kWh)}}{\text{maximum demand (kW)} \times \text{hours in year}}$
Low Voltage (LV)	Nominal voltages below 1kV.
LV Substation Tariff	This tariff applies as described in DCUSA Schedule 16 Section 141, Note 3, where the metering CT is within 10m by cable route of the HV/LV substation transformation chamber.
Market Domain Data (MDD)	MDD is a central repository of reference data available to all Users involved in Settlement. It is essential to the operation of SVA trading arrangements. More information can be found here Market Domain Data - Elexon BSC
Market Segment	<p>Market Segment is derived from the Meter Type and Connection Type using a defined set of business rules.</p> <p>There are three Market Segments:</p> <ul style="list-style-type: none"> • Smart and Non-Smart (Including Smart Meters with Settlement Period level data available, Smart Meters with only Register Readings available and Non-Smart Meters with Register Readings); • Advanced (which are Advanced Metering Systems with Settlement Period level data available); • Unmetered
Market-Wide HH Settlement (MHHS)	Market-wide Half-Hourly Settlement (MHHS) is a key enabler of the flexibility to support the transition to Net Zero. The MHHS Programme will contribute to a more cost-effective electricity system, encouraging more flexible use of energy and helping consumers lower their bills.
Maximum Export Capacity (MEC)	The MEC of apparent power expressed in kVA that has been agreed can flow through the entry point to the Distribution System from the Customer's installation as specified in the connection agreement.
Maximum Import Capacity (MIC)	The MIC of apparent power expressed in kVA that has been agreed can flow through the exit point from the Distribution System to the Customer's installation as specified in the connection agreement.

Term	Definition
Measurement Class	<p>A classification of Metering Systems used in the BSC which indicates how consumption is measured, i.e.:</p> <ul style="list-style-type: none"> • Measurement Class A – non-half hourly metering equipment; • Measurement Class B – non-half hourly unmetered supplies; • Measurement Class C – half hourly metering equipment at or above 100kW premises; • Measurement Class D – half hourly unmetered supplies; • Measurement Class E – half hourly metering equipment below 100kW premises with CT; • Measurement Class F – half hourly metering equipment at below 100kW premises with CT or whole current, and at domestic premises; and • Measurement Class G – half hourly metering equipment at below 100kW premises with whole current and not at domestic premises.
Meter Timeswitch Code (MTC)	<p>MTCs are three digit codes allowing suppliers to identify the metering installed in Customers' premises. They indicate whether the meter is single or multi-rate, pre-payment or credit, or whether it is 'related' to another meter. Further information can be found in MDD.</p>
Metering Point	<p>The point at which electricity that is exported to or imported from the licensee's Distribution System is measured, is deemed to be measured, or is intended to be measured and which is registered pursuant to the provisions of the REC. For the purposes of this statement, GSPs are not 'Metering Points'.</p>
Metering Point Administration Number (MPAN)	<p>A number relating to a Metering Point under the REC.</p>
Metering System	<p>Particular commissioned metering equipment installed for the purposes of measuring the quantities of exports and/or imports at the exit point or entry point.</p>
Metering System Identifier (MSID)	<p>MSID is a term used throughout the BSC and its subsidiary documents and has the same meaning as MPAN as used under the REC.</p>
Migrated MPANs	<p>Migration refers to the process by which MPANs are migrated from the legacy arrangements to the new MHHS arrangements.</p>
Nested Networks	<p>This refers to a situation where there is more than one level of Embedded Network and therefore nested Distribution Systems between LDNOs (e.g. host DNO → primary nested DNO → secondary nested DNO → customer).</p>
Non-Final Demand (NFD) Site	<p>As defined in DCUSA Schedule 32.</p>
Non-Migrated MPANs	<p>This refers to the status when an MPAN is on the legacy arrangements and before migrating under MHHS.</p>

Term	Definition
Ofgem	Office of Gas and Electricity Markets – Ofgem is governed by GEMA and is responsible for the regulation of the distribution companies.
Profile Class (PC)	A categorisation applied to NHH MPANs and used in settlement to group customers with similar consumption patterns to enable the calculation of consumption profiles.
Retail Energy Code (REC)	A code that consolidates the switching arrangements historically set out in the Master Registration Agreement (MRA) and the Supply Point Administration Agreement (SPAA) (for gas) into one dual-fuel code. Provides a governance mechanism to manage the processes established between electricity suppliers and distribution companies to enable electricity suppliers to transfer customers. It includes terms for the provision of Metering Point Administration Services (MPAS) Registrations.
Settlement	The determination and settlement of amounts payable in respect of charges (including reconciling charges) in accordance with the BSC.
Settlement Class (SC)	The combination of Profile Class, Line Loss Factor Class, Time Pattern Regime and Standard Settlement Configuration, by Supplier within a GSP group and used for Settlement.
Standard Settlement Configuration (SSC)	A standard metering configuration relating to a specific combination of Time Pattern Regimes.
Supercustomer	The method of billing Users for use of system on an aggregated basis, grouping together consumption and standing charges for all similar NHH metered Customers or aggregated HH metered Customers. Also referred to as Aggregate billing.
Supercustomer DUoS Report	A report of profiled data by Settlement Class providing counts of MPANs and units consumed.
Supplier	An organisation with a supply licence responsible for electricity supplied to and/or exported from a metering point.
Supplier Volume Allocation (SVA)	As defined in the BSC.
Time Pattern Regime (TPR)	The pattern of switching behaviour through time that one or more meter registers follow.
Unmetered Supplies	Exit points deemed to be suitable as unmetered supplies as permitted in the Electricity (Unmetered Supply) Regulations 2001 and where operated in accordance with BSC procedure 520 ¹² .
Use of System Charges	Charges which are applicable to those parties which use the Distribution System.

¹² Balancing and Settlement Code Procedures are available from <http://www.elexon.co.uk/pages/bscps.aspx>

Term	Definition
User	Someone that has a use of system agreement with the DNO e.g. a supplier, generator or other LDNO.

Appendix 2 - Guidance notes¹³

Background

- 1.1. The electricity bill from your Supplier contains an element of charge to cover electricity distribution costs. This distribution charge covers the cost of operating and maintaining a safe and reliable Distribution System that forms the 'wires' that transport electricity between the national transmission system and end users such as homes and businesses. Our Distribution System includes overhead lines, underground cables, as well as substations and transformers.
- 1.2. In most cases, your Supplier is invoiced for the distribution charge and this is normally part of your total bill. In some cases, for example business users, the Supplier may pass through the distribution charge as an identifiable line item on the electricity bill.
- 1.3. Where electricity is generated at a premises your Supplier may receive a credit for energy that is exported on to the Distribution System. These credits are intended to reflect that the exported generation may reduce the need for traditional demand led reinforcement of the Distribution System.
- 1.4. Understanding your distribution charges could help you reduce your costs and increase your credits. This is achieved by understanding the components of the charge to help you identify whether there may be opportunities to change the way you use the Distribution System.

Meter point administration

- 1.5. We are responsible for managing the electricity supply points that are connected to our Distribution System. Typically, every supply point is identified by a Meter Point Administration Number (MPAN). A few supply points may have more than one MPAN depending on the metering configuration (e.g. a school which may have an MPAN for the main supply and an MPAN for catering).
- 1.6. The full MPAN is a 21 digit number, preceded by an 'S' and includes supplementary data. The MPAN applicable to a supply point is found on the electricity bill from your Supplier. This number enables you to establish who your electricity distributor is, details of the characteristics of the supply and importantly the distribution charges that are applicable to your premises.

¹³ These guidance notes are provided for additional information and do not form part of the application of charges.

- 1.7. The 21-digit number is normally presented in two sections as shown in the following diagram. The top section is supplementary data which gives information about the characteristics of supply, while the bottom 'core' is the unique identifier.

Full MPAN diagram

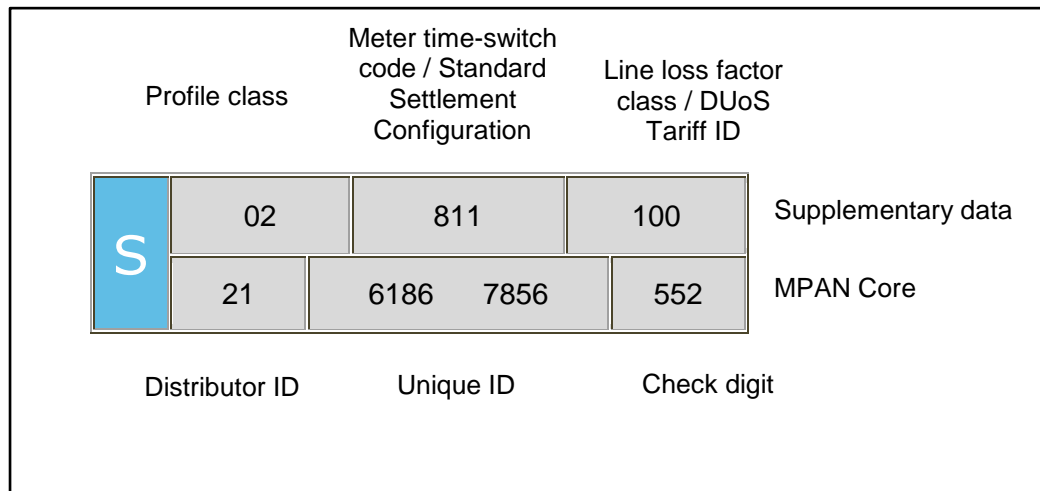

- 1.8. Generally, you will only need to know the Distributor ID and LLFC/DUoS Tariff ID to identify the distribution charges for your premises. However, there are some premises where charges are specific to that site. In these instances, the charges are identified by the MPAN core. The Distributor ID for SWAE is 21. Other Distributor IDs can be referenced in the glossary.

- 1.9. Additionally, it can be useful to understand the profile class provided in the supplementary data. The profile class will be a number between 00 and 08. The following list provides details of the allocation of profile classes to types of customers:

- '01' – Domestic customers with unrestricted supply
- '02' – Domestic customers with restricted load, for example off-peak heating
- '03' – Non-domestic customers with unrestricted supply
- '04' – Non-domestic customers with restricted load, for example off-peak heating
- '05' – Non-domestic maximum demand customers with a Load Factor of less than 20%
- '06' – Non-domestic maximum demand customers with a Load Factor between 20% and 30%
- '07' – Non-domestic maximum demand customers with a Load Factor between 30% and 40%

- '08' – Non-domestic maximum demand customers with a Load Factor over 40% or non-half hourly metered generation customers
 - '00' – Half-hourly metered, demand and generation customers (including all Migrated MPANs)
- 1.10. Unmetered Supplies will be allocated to profile class 01, 08 or 00 depending on the type of load or the measurement method of the load.
- 1.11. The allocation of the profile class will affect your charges for Non-Migrated MPANs. If you feel that you have been allocated the wrong profile class, please contact your Supplier as they are responsible for this.

Your charges

- 1.12. All distribution charges that relate to our Distributor ID 21 are provided in this statement.
- 1.13. You can identify your charges by referencing your LLFC/DUoS Tariff ID, from Annex 1. If the MPAN is for a Designated EHV Property, then the charges will be found in Annex 2. In a few instances, the charges may be contained in Annex 3 or Annex 6. When identifying charges in Annex 2, please note that some LLFC/DUoS Tariff IDs have more than one charge. In this instance, you will need to select the correct charge by cross-referencing with the MPAN core provided in the table.
- 1.14. Once you have identified which charge structure applies to your MPAN then you will be able to calculate an estimate of your distribution charge using the calculator provided in the spreadsheet 'Schedule of charges and other tables' found in the sheet called 'Charge Calculator'. This spreadsheet can be downloaded from www.nationalgrid.co.uk.

Reducing your charges

- 1.15. The most effective way to reduce your energy charges is to reduce your consumption by switching off or using more energy efficient appliances. However, there are also other potential opportunities to reduce your distribution charges; for example, it may be beneficial to shift demand or generation to a better time period. Demand use is likely to be cheaper outside peak periods and generation credits more beneficial during peak periods, although the ability to directly benefit will be linked to the structure of your supply charges.

- 1.16. The calculator mentioned above provides the opportunity to establish a forecast of the change in distribution charges that could be achieved if you are able to change any of the consumption related inputs.

Reactive power and reactive power charges

- 1.17. Reactive power is a separately charged component of connections that are half hourly metered. Reactive power charges are generally avoidable if 'best practice' design of the properties' electrical installation has been provided in order to maintain a power factor between 0.95 and unity at the Metering Point.
- 1.18. Reactive Power (kVArh) is the difference between working power (active power measured in kW) and total power consumed (apparent power measured in kVA). Essentially it is a measure of how efficiently electrical power is transported through an electrical installation or a Distribution System.
- 1.19. Power flowing with a power factor of unity results in the most efficient loading of the Distribution System. Power flowing with a power factor of less than 0.95 results in much higher losses in the Distribution System, a need to potentially provide higher capacity electrical equipment and consequently a higher bill for you the consumer. A comparatively small improvement in power factor can bring about a significant reduction in losses since losses are proportional to the square of the current.
- 1.20. Different types of electrical equipment require some 'reactive power' in addition to 'active power' in order to work effectively. Electric motors, transformers and fluorescent lighting, for example, may produce poor power factors due to the nature of their inductive load. However, if good design practice is applied then the poor power factor of appliances can be corrected as near as possible to source. Alternatively, poor power factor can be corrected centrally near to the meter.
- 1.21. There are many advantages that can be achieved by correcting poor power factor. These include: reduced energy bills through lower reactive charges, lower capacity charges and reduced power consumption and reduced voltage drop in long cable runs.

Site-specific EDCM charges

- 1.22. A site classified as a Designated EHV Property is subject to a locational-based charging methodology (referred to as EDCM) for higher voltage network users. Distributors use one of two approved approaches: Long Run Incremental Cost

(LRIC) or Forward Cost Pricing (FCP); we use the LRIC. The EDCM will apply to Customers connected at EHV or connected at HV and metered at an EHV/HV Substation.

1.23. EDCM charges and credits are site-specific, reflecting the degree to which the local and higher voltage networks have the capacity to serve more demand or generation without the need to upgrade the electricity infrastructure. The charges also reflect the networks specifically used to deliver the electricity to the site as well as the usage at the site. Generators with non-intermittent output and deemed to be providing beneficial support to our networks may qualify to receive credit.

1.24. The charges under the EDCM comprise of the following individual components:

a) **Fixed charge (pence/MPAN/day)** - This charge recovers operational costs associated with those connection assets that are provided for the 'sole' use of the customer and a residual amount to ensure recovery of our regulated allowed revenue.

b) **Capacity charge (pence/kVA/day)** - This charge comprises the relevant LRIC component, the National Grid Electricity Transmission cost and other regulated costs.

Capacity charges are levied on the MIC, MEC, and any exceeded capacity. You may wish to review your MIC or MEC periodically to ensure it remains appropriate for your needs as you may be paying for more capacity than you require. If you wish to make changes contact us via the details in paragraph 1.13

The LRIC cost is locational and reflects our assessment of future network reinforcement necessary at the voltage of connection (local) and beyond at all higher voltages (remote) relevant to the customer's connection. This results in the allocation of higher costs in more capacity congested parts of the network reflecting the greater likelihood of future reinforcement in these areas, and the allocation of lower costs in less congested parts of the network. The local LRIC cost is included in the capacity charge.

Our regulated costs include direct and indirect operational costs. The capacity charge recovers these costs using the customer usage profile and the relevant assets being used to transport electricity between the source substation and customer's Metering Point.

- c) **Super-red unit charge (pence/kWh)** - This charge recovers the remote LRIC component. The charge is positive for import and negative for export which means you can either reduce your charges by minimising consumption or increasing export at those times. The charge is applied to consumption during the Super-red time period as detailed in Annex 2.
- 1.25. Future charge rates may be affected by consumption during the Super-red period, therefore reducing consumption in the Super-red time period may be beneficial.
- 1.26. **Reactive Power** - The EDCM does not include a separate charge component for any reactive power flows (kVAr) for either demand or generation. However, the EDCM charges do reflect the effect on the network of the customer's power factor; for example, unit charges can increase if your site power factor is poor (lower than 0.95). Improving your site's power factor will also reduce the maximum demand (kVA) for the same power consumed in kW thus providing scope to reduce your agreed capacity requirements.

Appendix 3 – Non-Final Demand Site Certificate

A certificate set out in the form of the example shown below should be submitted to confirm that a site qualifies as a Non-Final Demand Site.

Non-Final Demand Site Certificate of Compliance	
<p>This is to certify that the Metering System listed below qualifies as compliant with the criteria of a Non-Final Demand Site, for the purposes of Use of System charges, and that:</p> <p>The property is a Single Site at which either or both Electricity Storage and/or Electricity Generation occurs (whether the facility(ies) at the site are operating or being commissioned, repaired or decommissioned), and that:</p> <ul style="list-style-type: none"> a) has an export Metering Point or Metering System and an import Metering Point or Metering System with associated metering equipment which only measures export from Electricity Storage and/or Electricity Generation and import for or directly relating to Electricity Storage and/or Electricity Generation (and not export from another source and/or import for another activity); and <ul style="list-style-type: none"> i) if registered in an MPAS Registration System, is subject to certification from a Supplier Party that the site meets the criteria in paragraph (a) above, which certificate has been provided to the DNO/IDNO Party; or ii) if registered in CMRS, is subject to certification from the Customer (or its CVA Registrant) that the site meets the criteria in paragraph (a) above, which certificate has been provided to the DNO/IDNO Party. <p>For the purposes of this declaration, the term Non-Final Demand Site has the meaning given to it in the DCUSA.</p>	
Metering System Site Address:	
Qualifying Import MPAN/MSID(s)	Qualifying Export MPAN/MSID(s)
<p>I declare that I understand the qualification requirements and certify that the above Metering System meets the criteria of a Non-Final Demand Site.</p> <p>Authorised signatory:</p> <p>Name and designation:</p> <p>On behalf of company:</p> <p>Date:</p>	

Annex 1 - Schedule of Charges for use of the Distribution System by LV and HV Designated Properties

National Grid Electricity Distribution (South Wales) plc - Effective from 1 April 2027 - Final LV and HV charges

Time Bands for LV and HV Designated Properties			
Time periods	Red Time Band	Amber Time Band	Green Time Band
Monday to Friday (Including Bank Holidays) All Year	17:00 to 19:30	07:30 to 17:00 19:30 to 22:00	00:00 to 07:30 22:00 to 24:00
Saturday and Sunday All Year		12:00 to 13:00 16:00 to 21:00	00:00 to 12:00 13:00 to 16:00 21:00 to 24:00
Notes	All the above times are in UK Clock time		

Time Bands for Unmetered Properties			
	Black Time Band	Yellow Time Band	Green Time Band
Monday to Friday (Including Bank Holidays) Nov to Feb Inclusive (excluding 22nd Dec to 4th Jan inclusive)	17:00 to 19:30	07:30 to 17:00 19:30 to 22:00	00:00 to 07:30 22:00 to 24:00
Monday to Friday (Including Bank Holidays) Mar to Oct Inclusive (plus 22nd Dec to 4th Jan inclusive)		07:30 to 22:00	00:00 to 07:30 22:00 to 24:00
Saturday and Sunday All year		12:00 to 13:00 16:00 to 21:00	00:00 to 12:00 13:00 to 16:00 21:00 to 24:00
Notes	All the above times are in UK Clock time		

Tariff name	Open LLFC/DUoS Tariff Id	PCs	Red/black unit charge p/kWh	Amber/yellow unit charge p/kWh	Green unit charge p/kWh	Fixed charge p/MPAN/day	Capacity charge p/kVA/day	Exceeded capacity charge p/kVA/day	Reactive power charge p/kVAh	Closed LLFC/DUoS Tariff Id
Domestic Aggregated or CT with Residual	100,105,800,860, 101,106,801,861, 116,D01	0, 1, 2	19.172	1.769	0.344	16.23				
Domestic Aggregated (Related MPAN)	194, 843	2	19.172	1.769	0.344					
Non-Domestic Aggregated or CT No Residual	N10,N20,N30,M10 ,B10,X10,X20,X30 ,Y10,Z10	0, 3, 4, 5-8	19.843	1.831	0.356	16.35				
Non-Domestic Aggregated or CT Band 1	1.2,3,117,200,201, 810,811,862,863, X11,X21,X31,Y11, Z11	0, 3, 4, 5-8	19.843	1.831	0.356	22.49				300, 344, 400
Non-Domestic Aggregated or CT Band 2	N12,N22,N32,M12 ,B12,X12,X22,X32 ,Y12,Z12	0, 3, 4, 5-8	19.843	1.831	0.356	33.37				
Non-Domestic Aggregated or CT Band 3	N13,N23,N33,M13 ,B13,X13,X23,X33 ,Y13,Z13	0, 3, 4, 5-8	19.843	1.831	0.356	52.17				
Non-Domestic Aggregated or CT Band 4	N14,N24,N34,M14 ,B14,X14,X24,X34 ,Y14,Z14	0, 3, 4, 5-8	19.843	1.831	0.356	108.73				
Non-Domestic Aggregated (related MPAN)	294	4	19.843	1.831	0.356					
LV Site Specific No Residual	L00, LST	0	12.754	1.111	0.232	18.62	11.06	11.06	0.309	
LV Site Specific Band 1	300	0	12.754	1.111	0.232	178.79	11.06	11.06	0.309	
LV Site Specific Band 2	L02	0	12.754	1.111	0.232	326.94	11.06	11.06	0.309	
LV Site Specific Band 3	L03	0	12.754	1.111	0.232	539.01	11.06	11.06	0.309	
LV Site Specific Band 4	L04	0	12.754	1.111	0.232	1243.10	11.06	11.06	0.309	
LV Sub Site Specific No Residual	S00, SST	0	8.276	0.607	0.157	14.54	10.38	10.38	0.188	
LV Sub Site Specific Band 1	344	0	8.276	0.607	0.157	174.70	10.38	10.38	0.188	
LV Sub Site Specific Band 2	S02	0	8.276	0.607	0.157	322.85	10.38	10.38	0.188	
LV Sub Site Specific Band 3	S03	0	8.276	0.607	0.157	534.92	10.38	10.38	0.188	
LV Sub Site Specific Band 4	S04	0	8.276	0.607	0.157	1239.01	10.38	10.38	0.188	
HV Site Specific No Residual	H00, HST	0	5.501	0.368	0.104	134.20	10.74	10.74	0.119	
HV Site Specific Band 1	400	0	5.501	0.368	0.104	1270.02	10.74	10.74	0.119	
HV Site Specific Band 2	H02	0	5.501	0.368	0.104	3093.63	10.74	10.74	0.119	
HV Site Specific Band 3	H03	0	5.501	0.368	0.104	5669.10	10.74	10.74	0.119	
HV Site Specific Band 4	H04	0	5.501	0.368	0.104	13094.04	10.74	10.74	0.119	
Unmetered Supplies	718, 701, 719, 720, 700	0, 1 or 8	62.704	3.825	2.348					
LV Generation Aggregated	697	0	-12.614	-1.164	-0.226	0.00				
LV Sub Generation Aggregated	717	0	-10.955	-0.978	-0.198	0.00				
LV Generation Site Specific	697, 603	0	-12.614	-1.164	-0.226	0.00			0.376	
LV Generation Site Specific no RP charge	91, 92	0	-12.614	-1.164	-0.226	0.00				
LV Sub Generation Site Specific	602, 604	0	-10.955	-0.978	-0.198	0.00			0.281	
LV Sub Generation Site Specific no RP charge	93, 94	0	-10.955	-0.978	-0.198	0.00				
HV Generation Site Specific	698, 606	0	-6.536	-0.479	-0.124	83.99			0.239	
HV Generation Site Specific no RP charge	95, 96	0	-6.536	-0.479	-0.124	83.99				

Note: Where a tariff only has a p/kWh unit rate in Unit Charge 1 then this unit rate applies at all times.

Annex 2 - Schedule of Charges for use of the Distribution System by Designated EHV Properties (including LDNOs with Designated EHV Properties/end-users).

National Grid Electricity Distribution (South Wales) plc - Effective from 1 April 2027 - Final Designated EHV charges

Time Periods for Designated EHV Properties	
Time periods	Super Red Time Band
Monday to Friday (Including Bank Holidays) November to February Inclusive (excluding 22nd Dec to 4th Jan Inclusive)	17:00 - 19:30
Notes	All the above times are in UK Clock time

Import Unique Identifier	LLFC/DUoS Tariff Id	Import MPANs/MSIDs	Export Unique Identifier	LLFC/DUoS Tariff Id	Export MPANs/MSIDs	Name	Residual Charging Band	Import Super Red unit charge (p/kWh)	Import fixed charge (p/day)	Import capacity charge (p/kVA/day)	Import exceeded capacity charge (p/kVA/day)	Export Super Red unit charge (p/kWh)	Export fixed charge (p/day)	Export capacity charge (p/kVA/day)	Export exceeded capacity charge (p/kVA/day)
121	121	2100041961757	327	327	2100041961766	Hopkins Farm 33kV PV		0.085	16.53	1.83	1.83		2200.27	0.05	0.05
122	122	2100041990623	328	328	2100041990632	Mynydd Yr Aber WIND Feeder 2			38.27	1.17	1.17		2012.92	0.05	0.05
123	123	2100042007363	329	329	2100042007372	Bryn Y Rhyd		0.085	42.63	0.91	0.91		5853.51	0.05	0.05
124	124	2100042049902	330	330	2100042050182	Coed Ely Solar Farm			6.67	1.83	1.83		680.76	0.05	0.05
181	181	2100042063039	432	432	2100042063386	PENCOED STOR 132kV		0.001	7.73	1.52	1.52	-0.001	3256.42	0.05	0.05
311	311	2100041665716	637	637	2100041665725	Afon Llan 33kV PV			56.62	1.45	1.45		5096.22	0.05	0.05
312	312	2100041707881	638	638	2100041707890	Hendy 66kV WF		7.866	14.71	10.68	10.68		1075.12	0.05	0.05
313	313	2100041731713 2100041731722 2100041731731				Sofidel	2	1.870	27849.78	4.41	4.41				
419	419	2100041256896	425	425	2100041256901	Mynydd Y Bwlfa WF		0.003	30.21	1.22	1.22		1450.19	0.05	0.05
420	420	2100041327873	426	426	2100041327882	Western Wood 2 Biomass	2		21101.01	1.26	1.26	-0.008	2325.56	0.05	0.05
421	421	2100041453132	427	427	2100041453141	Mynydd Y Gwair WF			14.49	1.23	1.23		2376.69	0.05	0.05
460	460	2100041270311	975	975	2100041270320	Penrhiwarth Farm PV		17.905	23.94	2.00	2.00		1464.97	0.05	0.05
462	462	2100041272860	976	976	2100041272870	Little Neath PV		0.941	10.80	3.21	3.21		1799.67	0.05	0.05
463	463	2100041136537	943	943	2100041136546	Hoplass Farm PV		0.941	5.22	3.26	3.26		1566.09	0.05	0.05
464	464	2100041278152	977	977	2100041278161	Gelliwern Isaf PV			3.71	2.53	2.53		741.89	0.05	0.05
465	465	2100041290958	978	978	2100041290967	Oak Cottage PV		1.742	162.43	2.04	2.04		12425.90	0.05	0.05
466	466	2100041309926	979	979	2100041309935	Red Court Farm PV		5.888	5.38	2.73	2.73		861.41	0.05	0.05
467	467	2100041319358	980	980	2100041319367	Carn Nicholas PV		0.279	18.46	1.37	1.37		1476.91	0.05	0.05
468	468	2100041320646	981	981	2100041320655	Brynwhilach Farm PV			70.79	1.21	1.21		1321.92	0.05	0.05
469	469	2100041320682	982	982	2100041320691	Pant Y Moch PV1		1.842	7.32	2.68	2.68		1300.26	0.05	0.05
470	470	2100041321808	983	983	2100041321817	Jesus College PV		0.154	4.99	3.53	3.53		848.52	0.05	0.05
471	471	2100041322183	984	984	2100041322192	Sully Moors STOR		0.151	7.44	1.78	1.78	-0.151	679.99	0.05	0.05
472	472	2100041330919	985	985	2100041330928	Hafod y Dafal PV		17.745	81.57	1.47	1.47		5089.91	0.05	0.05
475	475	2100041336488	988	988	2100041336497	Canin Energy Park T1 WT			7.29	1.01	1.01		78.71	0.05	0.05
476	476	2100041336716	989	989	2100041336725	Stormy Down PV			14.17	1.54	1.54		673.26	0.05	0.05
477	477	2100041336734	721	721	2100041336743	Oak Grove Farm PV		1.673	3.43	1.99	1.99		858.51	0.05	0.05
478	478	2100041329063	722	722	2100041329072	Llancahle Farm PV		0.044	40.86	1.62	1.62		796.84	0.05	0.05
479	479	2100041339178	723	723	2100041339187	Lower House Farm PV		8.180	244.90	1.93	1.93		10775.56	0.05	0.05
480	480	2100041343582	724	724	2100041343607	Derwyn PV		0.154	9.85	1.52	1.52		787.88	0.05	0.05
481	481	2100041343936	725	725	2100041343945	Rosedew PV		0.045	62.79	1.77	1.77		1649.10	0.05	0.05
482	482	2100041344647	726	726	2100041344656	Pen Rhiw Caradog PV		0.013	20.62	1.60	1.60		849.41	0.05	0.05
483	483	2100041345400	727	727	2100041345419	Mynydd Y Gwrhyd WF		0.074	313.09	1.05	1.05	-0.136	1471.52	0.05	0.05
484	484	2100041346894	728	728	2100041346900	Tonypandy STOR			10.65	5.53	5.53	-6.023	1118.67	0.05	0.05
485	485	2100041346867	729	729	2100041346885	Traston Road STOR		0.023	9.42	2.32	2.32	-0.023	991.49	0.05	0.05
486	486	2100041347202	730	730	2100041347211	Maesgwyn Extension WF		0.081	28.72	1.24	1.24		359.04	0.05	0.05
487	487	2100041363418	731	731	2100041363427	Manor Farm PV		17.813	14.03	1.63	1.63		1080.23	0.05	0.05
488	488	2100041376426	732	732	2100041376435	Pant Y Moch PV2		1.842	7.32	2.10	2.10		1300.26	0.05	0.05
489	489	2100041355189	733	733	2100041355198	Rhewl Farm PV		1.678	15.69	1.31	1.31		941.59	0.05	0.05
491	491	2100041383511	735	735	2100041383520	Bargoed PV	1	0.042	2009.35	1.82	1.82		679.11	0.05	0.05
492	492	2100041383822	736	736	2100041383831	Mynydd Brombil WF		1.847	162.23	1.18	1.18		5464.48	0.05	0.05
493	493	2100041383840	737	737	2100041383850	Rassau Ind Est STOR		0.167	54.19	1.46	1.46	-0.167	4055.66	0.05	0.05
494	494	2100041394105	738	738	2100041394114	Llynfi Afan WF	1		2064.88	1.23	1.23		6451.63	0.05	0.05
495	495	2100041394123	739	739	2100041394132	Mynydd Yr Aber 66kV WF			153.07	1.06	1.06		8051.70	0.05	0.05
496	496	2100041401774	740	740	2100041401792	Waun Y Pound 1 STOR		0.170	7.07	1.78	1.78	-0.170	680.36	0.05	0.05
497	497	2100041403638	741	741	2100041403647	Cockett Valley PV		0.132	10.19	3.63	3.63		2079.82	0.05	0.05
498	498	2100041403656	742	742	2100041403665	Nathenfoel PV		9.047	2.67	5.64	5.64		1121.05	0.05	0.05
499	499	2100041403674	743	743	2100041403683	Waun Y Pound 2 STOR		0.170	8.07	1.10	1.10	-0.170	679.36	0.05	0.05

Note: The list of MPANs / MSIDs provided may be incomplete; the DNO reserves the right to apply the listed charges to any other MPANs / MSIDs associated with the site.

Annex 2 - Schedule of Charges for use of the Distribution System by Designated EHV Properties (including LDNOs with Designated EHV Properties/end-users).

Import Unique Identifier	LLFC/DUoS Tariff Id	Import MPANs/MSIDs	Export Unique Identifier	LLFC/DUoS Tariff Id	Export MPANs/MSIDs	Name	Residual Charging Band	Import Super Red unit charge (p/kWh)	Import fixed charge (p/day)	Import capacity charge (p/kVA/day)	Import exceeded capacity charge (p/kVA/day)	Export Super Red unit charge (p/kWh)	Export fixed charge (p/day)	Export capacity charge (p/kVA/day)	Export exceeded capacity charge (p/kVA/day)
500	500	2100041407767	744	744	2100041407776	St Peters Church WF			103.23	1.14	1.14		4829.85	0.05	0.05
504	504	2100040007060				Corus Trostre	4	1.839	121096.54	3.50	3.50				
		2100040007079													
		2100040007088													
		2100040007097													
		2100040007102													
		2100040007111													
		2100040007120													
		2100040007130													
2100040014545															
218999999714															
507	507	2100040067486	664	664	2100040067477	ABB Connelly			52.17	1.18	1.18		1669.42	0.05	0.05
508	508	2100041079038	674	674	2100041079047	Bettws			20.81	1.32	1.32		1539.59	0.05	0.05
509	509	2100040126342	660	660	2100040126333	Blaen Bowi		7.943	20.39	3.59	3.59				
510	510	2199989614144				Mir Steel	2		23395.71	0.81	0.81				
511	511	2199989271918				Boc Margam	4			122817.71	1.93	1.93			
		2199989271927													
		2199989271936													
		2199989610089													
513	513	2199989616995				Alcoa	2		21874.62	1.28	1.28				
514	514	218999999928				Celsa Rod Mills	4	0.035	134558.78	2.79	2.79				
515	515	2199989638961				Puma Energy (ex Murphy Oil)	1	1.410	20957.44	3.12	3.12				
		2199989638970													
518	518	2189999996884	619	619	2100040023638 2100040023647	Interbrew Magor USKM	2	1.786	21140.00	4.11	4.11		118.57	0.05	0.05
519	519	2199989611204				Mainline Pipelines	1	0.717	2178.88	2.83	2.83				
520	520	2189999999937				Celsa 33 11	3		59567.41	2.28	2.28				
522	522	2199989628537				Lafarge - Blue Circle	3	0.040	52182.87	2.62	2.62				
529	529	2189999997284				Inco	2	0.255	23458.41	3.08	3.08				
532	532	2199989640232				DCWW Nantgaredig	2	4.855	21874.62	5.41	5.41				
533	533	2100041701230	633	633	2198765427530	Bridgend Paper Mill	4	3.999	124920.49	2.07	2.07		1157.82	0.05	0.05
		2100041701259													
		2100041701268													
		2199989633165													
		2199989633174													
2199989633183															
534	534	2189999997451 2189999997460 2189999997683				Momentive Chemicals	1	0.174	2534.59	2.57	2.57				
535	535	2189999998924	617	617	2100040890412 2100040890430 2100040890440 2100040890459	Monsanto	3	0.024	50900.25	2.58	2.58		209.47	0.05	0.05
		2189999998933													
		2189999998942													
		2199989663578													
536	536	2199989353701 2199989353710	636	636	2189999997354	Dow Corning	3		51215.79	4.78	4.78		545.00	0.05	0.05
538	538	2198765295402	786	786	2100041213572	DCWW Rover Way	2	0.035	21122.28	3.19	3.19		136.30	0.05	0.05
539	539	2100040302060				Simms metals	1		3556.42	2.19	2.19				
541	541	2100040752410 2100040752420	678	678	2100040752396 2100040752401	Millford Energy	4	0.755	119013.63	3.11	3.11	-0.755	183.99	0.05	0.05
542	542	2100040636538				South Hook	4	1.901	153848.55	4.08	4.08				
		2100040653932													
545	545	2100040769015				Felindre	4			128644.24	1.16	1.16			
		2100040769033													
		2100040769042													
546	546	2100040781360				Timet	2		21874.62	2.36	2.36				
		2100040781379													
547	547	2100040495610	663	663	2100040495600	Blaen Cregan			6.26	9.87	9.87				
548	548	2100040878007	668	668	2100040878016	Blaengwen Wind Farm		1.187	1138.33	5.27	5.27		26181.68	0.05	0.05
549	549	2100041471220	651	651	2100041471239 2199989632384	Bryn Titti Wind Farm	1	7.930	29.00	10.79	10.79		1063.25	0.05	0.05
		2199989632384													
571	571	2100040067538	665	665	2100040067529	Crymlin Burrows	1	0.288	2611.59	1.61	1.61				
572	572	2199989635669	652	652	2189999997390	Dyffryn Brodyn Wind Farm		6.070	11.27	3.20	3.20		676.16	0.05	0.05
574	574	2199989614809	653	653	2199989612769	Llyn Brianne		5.508	118.99	6.15	6.15	-15.188	7139.34	0.05	0.05
575	575	2100041079171	676	676	2100041079180	Maerdy		0.053	50.59	1.87	1.87		4047.07	0.05	0.05
576	576	2100041416441	773	773	2100041416450	HIRWAUN GE 33kV GEN	1	0.053	2240.07	1.10	1.10	-0.053	1887.27	0.05	0.05
577	577	2100040719992	661	661	2100040719983	Margam Biomass			8608.79	1.13	1.13		8608.79	0.05	0.05
579	579	2100040485950	670	670	2100040485940	Pwllfa Gwatkin	1	0.039	2048.76	1.21	1.21				
580	580	2199989641937	650	650	2189999997345	Taff Ely Wind Farm			9.26	3.68	3.68		1019.03	0.05	0.05

Note: The list of MPANs / MSIDs provided may be incomplete; the DNO reserves the right to apply the listed charges to any other MPANs / MSIDs associated with the site.

Annex 2 - Schedule of Charges for use of the Distribution System by Designated EHV Properties (including LDNOs with Designated EHV Properties/end-users).

Import Unique Identifier	LLFC/DUoS Tariff Id	Import MPANs/MSIDs	Export Unique Identifier	LLFC/DUoS Tariff Id	Export MPANs/MSIDs	Name	Residual Charging Band	Import Super Red unit charge (p/kWh)	Import fixed charge (p/day)	Import capacity charge (p/kVA/day)	Import exceeded capacity charge (p/kVA/day)	Export Super Red unit charge (p/kWh)	Export fixed charge (p/day)	Export capacity charge (p/kVA/day)	Export exceeded capacity charge (p/kVA/day)
581	581	2100040609516	662	662	2100040609507	Trecatti	1	0.041	2216.27	1.00	1.00	-0.041	1291.44	0.05	0.05
582	582	2100040694060	666	666	2100040694051	Withyhedges Landfill	1	1.771	2024.02	1.86	1.86	-3.398	885.40	0.05	0.05
583	583	2198765146436	659	659	2198765142992	Parc Cynog		6.018	4.10	2.85	2.85				
584	584	2100040841771	667	667	2100040841780	Parc Cynog (Pendine)		6.018	39.88	2.54	2.54		696.03	0.05	0.05
585	585	2100040960600	684	684	2100040960619	Maesgwyn			147.56	1.24	1.24		7673.07	0.05	0.05
586	586	2100040989413	679	679	2100040989431	Ferndale Wind Farm			60.03	3.77	3.77		1921.03	0.05	0.05
587	587	2100041090096	685	685	2100041090087	Pant y Wal WF			60.95	8.47	8.47		5693.15	0.05	0.05
588	588	2100041063650	686	686	2100041063669	Mynydd Portref			25.51	3.41	3.41		1700.92	0.05	0.05
589	589	2100041383878	687	687	2100041383887	Newton Down			14.07	1.08	1.08		673.36	0.05	0.05
590	590	2100041200253	649	649	2100041200262	Tiers Cross PV			17.20	2.72	2.72		1755.68	0.05	0.05
593	593	2189999997503 2189999997512				Thyssenkrup Camford Pressing	2	3.334	20902.86	3.22	3.22				
594	594	2189999997025 2189999997034 2189999997043				Hoover	1	0.924	2534.59	1.50	1.50				
610	610	2100041407749	745	745	2100041407758	Berthllwyd PV			7.16	2.07	2.07		1218.35	0.05	0.05
612	612	2100041412093	747	747	2100041412109	Whitton Mawr PV		0.154	16.25	1.48	1.48		714.81	0.05	0.05
613	613	2100041412118	748	748	2100041412127	Barry Dock Biomass		0.156	259.88	1.64	1.64	-0.156	2970.49	0.05	0.05
614	614	2100041412172	749	749	2100041412181	North Tenement PV		3.350	60.83	3.01	3.01		2767.64	0.05	0.05
615	615	2100041416423	772	772	2100041416432	Bryncymau Isaf PV		5.622	31.68	3.61	3.61		2047.02	0.05	0.05
620	620	2199989611348				University Hospital of Wales	2	0.700	21258.57	2.24	2.24				
622	622	2199989609970	New Export 40	New Export 40	New Export 40	QuinetIQ	1	8.810	2064.55	2.41	2.41		114.34	0.05	0.05
623	623	2100041070815 2100041071828				Western Coal	1	0.101	2972.78	6.05	6.05				
625	625	2100040983990	658	658	2199989641360	Tregaron	1	10.338	2002.79	1.00	1.00	-10.338	176.09	0.05	0.05
627	627	2100041072798	646	646	2100041072803	Wauanrlydd STOR	1	0.130	2005.32	1.02	1.02	-0.130	859.27	0.05	0.05
628	628	2100041078805	645	645	2100041078814	Briton Ferry BESS 33KV		1.827	705.40	1.10	1.10	-1.881	730.93	0.05	0.05
629	629	2100041089700	644	644	2100041089685	Hirwaun BESS 33KV		0.087	1015.69	1.10	1.10	-0.087	1052.45	0.05	0.05
631	631	2100041080121	643	643	2100041080130	Ffos Las PV		1.793	21.11	2.39	2.39		1055.45	0.05	0.05
632	632	2100041080140	642	642	2100041080177	Pont Andrew PV		1.789	21.48	1.87	1.87		1073.91	0.05	0.05
634	634	2100041495912	922	922	2100041495921	Beaufort Power STOR		0.123	302.08	1.10	1.10	-0.123	9919.00	0.05	0.05
635	635	2100041611942	695	695	2100041611951	Cenin Energy Park ParcStormy	1		2132.21	1.01	1.01		154.51	0.05	0.05
671	671	2100041495940	921	921	2100041495959	Brecon Power STOR		0.111	349.25	1.18	1.18	-0.111	11103.12	0.05	0.05
672	672	2100041611960	696	696	2100041611970	Cenin Energy Park Battery			194.35	1.00	1.00		194.35	0.05	0.05
680	680	2100041526631	990	990	2100041526640	Bryn Blaen WF		7.930	25.67	10.70	10.70		1071.00	0.05	0.05
681	681	2100041539170	991	991	2100041539180	Ystradffin Hydro		5.531	10.88	6.12	6.12	-15.253	725.03	0.05	0.05
682	682	2100041620352	992	992	2100041620361	Bryn Henllys 33kV PV	1	0.053	2042.94	1.92	1.92		11029.87	0.05	0.05
688	688	2100041546201 2100041546674				Swansea University	2	0.142	28788.93	2.96	2.96				
689	689	2100041611915	690	690	2100041611924	Cenin Energy Park T2 WT			7.29	1.12	1.12		204.07	0.05	0.05
750	750	2100041422668	779	779	2100041422677	Brechfa Forest West WF			1167.36	1.33	1.33		141250.48	0.05	0.05
751	751	2100041566217 2100041566341				Pembroke Refinery	4		156718.78	2.90	2.90				
752	752	2100041612468	428	428	2100041612477	LLANWERN FM 132kV GEN			2.52	4.27	4.27		1517.88	0.05	0.05
760	760	2100041324775				Pen Y Cymoedd WF Aux.	1	0.061	5870.11	1.48	1.48				
761	761	2100041490037	789	789	2100041490046	Afan Way STOR		1.816	14.13	1.94	1.94	-1.816	1130.15	0.05	0.05
762	762	2100041418350	774	774	2100041418360	Manmool PV		17.707	92.70	1.18	1.18		3214.06	0.05	0.05
763	763	2100041438659	775	775	2100041438668	Maesgwyn Extension PV		0.081	14.36	1.28	1.28		396.81	0.05	0.05
764	764	2100041444801	776	776	2100041444810	Crumlin STOR		17.568	20.87	1.54	1.54	-17.568	1255.50	0.05	0.05
765	765	2100041445958	777	777	2100041445967	Pen Bryn Oer WF		0.042	70.31	1.08	1.08		2221.83	0.05	0.05
880	880	2189999997595 2189999997600	601	601	2189999998739	Tata Margam	4		118841.91	1.84	1.84				
882	882	2100041103391	790	790	2100041103407	Tir John BESS 33KV		0.279	645.83	1.12	1.12	-0.306	730.71	0.05	0.05
883	883	2100041105593	940	940	2100041105609	Wear Point WF		1.480	22.53	1.15	1.15		3218.49	0.05	0.05
884	884	2100041113229	791	791	2100041113247	West Farm PV		1.053	8.66	1.35	1.35		766.03	0.05	0.05
885	885	2100041113326	792	792	2100041113335	Jordanston Farm PV		0.957	4.67	4.52	4.52		1062.49	0.05	0.05
886	886	2100041115787	793	793	2100041115796	Rudbaxton PV		1.766	15.50	3.82	3.82		2821.04	0.05	0.05
888	888	2100041120350	942	942	2100041120360	Dowlais STOR	1	0.041	3238.47	0.91	0.91	-0.041	1302.53	0.05	0.05
890	890	2100041142372	944	944	2100041142381	Trident Park Recovery		0.030	2379.66	1.13	1.13	-0.031	17525.74	0.05	0.05
891	891	2100041150763	945	945	2100041150772	Baglan Bay PV		1.828	16.76	2.89	2.89		4190.79	0.05	0.05
892	892	2100041150781	946	946	2100041150790	Caermelyn PV		1.913	6.89	4.78	4.78		688.63	0.05	0.05
893	893	2100041150833	947	947	2100041150842	Liddlestone Ridge PV	1	2.227	2005.30	6.63	6.63		896.46	0.05	0.05
894	894	2100041172093	948	948	2100041172109	Garn Farm PV		0.155	50.32	1.14	1.14		805.16	0.05	0.05
896	896	2100041195090	950	950	2100041195106	Treguff Farm PV		0.045	18.62	2.24	2.24		707.59	0.05	0.05
897	897	2100041197887	951	951	2100041197896	Loughor Solar Park		0.045	4.74	2.64	2.64		739.25	0.05	0.05
898	898	2100041197869	952	952	2100041197878	Sutton Farm PV		0.154	28.30	1.53	1.53		2263.70	0.05	0.05
899	899	2100041201318	953	953	2100041201327	Cefn Betingau PV			1.95	3.45	3.45		701.64	0.05	0.05
900	900	2100041201293	954	954	2100041201309	Clawdd Ddu PV		0.085	3.80	4.71	4.71		1557.82	0.05	0.05

Note: The list of MPANs / MSIDs provided may be incomplete; the DNO reserves the right to apply the listed charges to any other MPANs / MSIDs associated with the site.

Annex 2 - Schedule of Charges for use of the Distribution System by Designated EHV Properties (including LDNOs with Designated EHV Properties/end-users).

Import Unique Identifier	LLFC/DUoS Tariff Id	Import MPANs/MSIDs	Export Unique Identifier	LLFC/DUoS Tariff Id	Export MPANs/MSIDs	Name	Residual Charging Band	Import Super Red unit charge (p/kWh)	Import fixed charge (p/day)	Import capacity charge (p/kVA/day)	Import exceeded capacity charge (p/kVA/day)	Export Super Red unit charge (p/kWh)	Export fixed charge (p/day)	Export capacity charge (p/kVA/day)	Export exceeded capacity charge (p/kVA/day)
901	901	2100041212221	955	955	2100041212230	Pentre Solar Farm		1.789	385.96	1.97	1.97		3859.62	0.05	0.05
903	903	2100041230833	957	957	2100041230842	Fenton Farm PV		1.741	7.46	5.03	5.03		5371.60	0.05	0.05
904	904	2100041240344	958	958	2100041240353	Yarbeston Gate Farm PV		1.742	27.19	1.94	1.94		2718.86	0.05	0.05
905	905	2100041251258	959	959	2100041251267	Pen Y Cae PV		0.085	9.00	2.15	2.15		1193.90	0.05	0.05
906	906	2100041251276	960	960	2100041251285	Saron PV		0.085	25.00	2.00	2.00		3091.09	0.05	0.05
907	907	2100041254969	961	961	2100041254978	Hendre Fawr PV		0.097	2.48	3.14	3.14		843.21	0.05	0.05
908	908	2100041257250	962	962	2100041257269	Hendai Farm PV		0.044	4.70	2.69	2.69		782.92	0.05	0.05
909	909	2100041258591	963	963	2100041258607	Cwm Cae Singrug PV		17.819	8.50	2.22	2.22		850.21	0.05	0.05
910	910	2100041252819	964	964	2100041252837	Brynteg Farm PV		1.776	7.03	2.68	2.68		754.73	0.05	0.05
911	911	2100041260304	965	965	2100041260313	Court Coleman PV		0.245	24.90	4.49	4.49		7470.03	0.05	0.05
912	912	2100041260331	966	966	2100041260340	Llwyndu Farm PV		8.800	3.33	8.31	8.31		726.11	0.05	0.05
914	914	2100041260633	968	968	2100041260642	Abergelli Farm PV			125.90	1.32	1.32		5847.81	0.05	0.05
915	915	2100041264080	969	969	2100041264099	Crug Mawr Farm PV		8.756	9.30	8.37	8.37		2232.60	0.05	0.05
916	916	2100041265516	970	970	2100041265525	Yerbeston Chapel Hill PV		0.936	97.42	1.47	1.47		7793.57	0.05	0.05
917	917	2100041265809	971	971	2100041265818	Aberaman Park Phase 2		0.013	46.48	1.72	1.72	-0.453	3635.39	0.05	0.05
918	918	2100041267912	972	972	2100041267930	Rhyd-y-Pandy PV			9.59	2.09	2.09		1918.83	0.05	0.05
919	919	2100041268837	973	973	2100041268846	Haverfordwest PV		1.741	9.17	2.55	2.55		1834.78	0.05	0.05
920	920	2100041269812	974	974	2100041269821	Blaenllidi Farm WF		1.789	23.26	2.00	2.00		1163.07	0.05	0.05
2614	2614	2614				Aberystwyth - Manweb	4	0.540	118841.91	8.49	8.49				
7159	7159	7159	7159	7159	7159	Solutia District Energy Newport		0.023	11.08	1.57	1.57	-0.008	323.82	0.05	0.05
7163	7163	7163	7163	7163	7163	Aberaman Park		0.013	44.82	1.71	1.71	-0.185	1310.19	0.05	0.05
7328	7328	7328	7329	7329	7329	Dowlais II STOR CVA		0.041	46.24	0.92	0.92	-0.041	2540.60	0.05	0.05
7346	7346	7346	7347	7347	7347	Alcoa B STOR			41.11	1.18	1.18		1821.82	0.05	0.05
7450	7450	7450				Rassau Grid Stability			11354.29	0.90	0.90				
7486	7486	7486	7487	7487	7487	Llandarcy STOR		0.277	25.08	1.30	1.30	-0.277	1003.30	0.05	0.05
7488	7488	7488	7489	7489	7489	Barry STOR		0.133	16.77	1.33	1.33	-0.133	670.67	0.05	0.05
7619	7619	7619	7620	7620	7620	Newport BESS (Formerly Traston Road Battery Storage)		0.023	777.13	0.94	0.94	-0.023	777.17	0.05	0.05
New Import 1	New Import 1	New Import 1				Bro Tathan 33kV	4	0.040	119813.66	5.88	5.88				
New Import 2	New Import 2	New Import 2				Manorafon 33kV	1	3.993	2513.67	5.83	5.83				
New Import 3	New Import 3	New Import 3				Phoenix Wharf	4		152368.41	0.91	0.91				
New Import 4	New Import 4	New Import 4				Plasdwr	3		53025.53	2.96	2.96				
New Import 5	New Import 5	New Import 5				Vantage	4	0.167	147823.68	1.88	1.88				
New Import 6	New Import 6	New Import 6	New Export 6	New Export 6	New Export 6	Abergorki WF 33kV		0.053	47.40	1.15	1.15		4138.17	0.05	0.05
New Import 7	New Import 7	New Import 7	New Export 7	New Export 7	New Export 7	Barry Solar Park			21.54	2.02	2.02		2046.47	0.05	0.05
New Import 8	New Import 8	New Import 8	New Export 8	New Export 8	New Export 8	BLACKBERRY LANE 33kV		0.926	52.44	2.26	2.26		5191.75	0.05	0.05
New Import 9	New Import 9	New Import 9	New Export 9	New Export 9	New Export 9	Bryntail Solar Park			58.42	2.22	2.22		7550.99	0.05	0.05
New Import 10	New Import 10	New Import 10	New Export 10	New Export 10	New Export 10	Brynwell Farm		0.135	76.09	4.26	4.26		7763.95	0.05	0.05
New Import 11	New Import 11	New Import 11	New Export 11	New Export 11	New Export 11	Caenewydd 132kV PV & BESS			3583.89	1.58	1.58		3772.53	0.05	0.05
New Import 12	New Import 12	New Import 12	New Export 12	New Export 12	New Export 12	Coedarrhydyglyn IDNO			15.63	2.05	2.05		1514.77	0.05	0.05
New Import 13	New Import 13	New Import 13	New Export 13	New Export 13	New Export 13	Coity Road		0.245	591.90	2.10	2.10	-2.230	623.06	0.05	0.05
New Import 14	New Import 14	New Import 14	New Export 14	New Export 14	New Export 14	Coity Walia Area			829.22	0.81	0.81		58189.20	0.05	0.05
New Import 15	New Import 15	New Import 15	New Export 15	New Export 15	New Export 15	Craig Y Perchych Solar Park			44.98	2.63	2.63		3551.02	0.05	0.05
New Import 16	New Import 16	New Import 16	New Export 16	New Export 16	New Export 16	Cwm Ifor 33kV PV		0.003	3.45	1.92	1.92		1056.25	0.05	0.05
New Import 17	New Import 17	New Import 17	New Export 17	New Export 17	New Export 17	ENVIRO PARKS 33kV GEN		0.087	352.05	1.22	1.22	-0.087	2640.37	0.05	0.05
New Import 18	New Import 18	New Import 18	New Export 18	New Export 18	New Export 18	Fonmon Solar Farm		0.044	8.46	2.02	2.02		3468.72	0.05	0.05
New Import 19	New Import 19	New Import 19	New Export 19	New Export 19	New Export 19	GCRE	4		120712.66	3.45	3.45		756.48	0.05	0.05
New Import 20	New Import 20	New Import 20	New Export 20	New Export 20	New Export 20	Great House Farm		0.014	15.07	3.78	3.78		1540.33	0.05	0.05
New Import 21	New Import 21	New Import 21	New Export 21	New Export 21	New Export 21	Carmel Road Solar PV (Formerly Gwenlais Solar Farm)			4.20	3.65	3.65		683.23	0.05	0.05
New Import 22	New Import 22	New Import 22	New Export 22	New Export 22	New Export 22	Ipswich Road			4638.20	0.88	0.88		4882.29	0.05	0.05
New Import 23	New Import 23	New Import 23	New Export 23	New Export 23	New Export 23	Lambeeth Solar Farm IDNO			1293.76	0.75	0.75		1361.85	0.05	0.05
New Import 24	New Import 24	New Import 24	New Export 24	New Export 24	New Export 24	Longlands Solar Park 33kV PV			15.88	3.71	3.71		1539.52	0.05	0.05
New Import 25	New Import 25	New Import 25	New Export 25	New Export 25	New Export 25	Maesmawr Solar Park			178.94	1.63	1.63		3844.02	0.05	0.05
New Import 26	New Import 26	New Import 26	New Export 26	New Export 26	New Export 26	Magor Net Zero Renewables Site	4		121469.15	3.44	3.44				
New Import 27	New Import 27	New Import 27	New Export 27	New Export 27	New Export 27	Manmoel 33kV WF		0.232	27.87	1.19	1.19		2598.61	0.05	0.05
New Import 28	New Import 28	New Import 28	New Export 28	New Export 28	New Export 28	Mynydd Garn Y Cefn		17.587	259.35	1.10	1.10		20507.67	0.05	0.05
New Import 29	New Import 29	New Import 29	New Export 29	New Export 29	New Export 29	Mynydd Ffiorch-dwm 33kV WF		1.828	139.26	1.35	1.35		15245.60	0.05	0.05
New Import 30	New Import 30	New Import 30	New Export 30	New Export 30	New Export 30	Oaklands Farm			747.65	2.89	2.89		762.75	0.05	0.05
New Import 31	New Import 31	New Import 31	New Export 31	New Export 31	New Export 31	Pen Onn Solar Park			3.30	1.98	1.98		1602.10	0.05	0.05
New Import 32	New Import 32	New Import 32	New Export 32	New Export 32	New Export 32	Penltergaer Solar Park 33kV			41.85	1.89	1.89		4404.86	0.05	0.05
New Import 33	New Import 33	New Import 33	New Export 33	New Export 33	New Export 33	Pentrebach 66kV PV		2.025	8.37	1.86	1.86		1897.39	0.05	0.05
New Import 34	New Import 34	New Import 34	New Export 34	New Export 34	New Export 34	Point Lane PV 33kV		1.034	31.08	1.95	1.95		712.91	0.05	0.05
New Import 35	New Import 35	New Import 35	New Export 35	New Export 35	New Export 35	SOUTHBOOK STOR 33kV GEN		1.664	10.06	1.45	1.45	-1.823	2012.83	0.05	0.05
New Import 36	New Import 36	New Import 36	New Export 36	New Export 36	New Export 36	Tonmawr Farm PV 33kV			25.32	2.74	2.74		7491.55	0.05	0.05
New Import 37	New Import 37	New Import 37				Tredwr DC Phase 1	3	0.031	55910.53	3.43	3.43				
New Import 38	New Import 38	New Import 38	New Export 38	New Export 38	New Export 38	Wauntysswg Park 33kV PV		0.234	11.31	2.27	2.27		11545.23	0.05	0.05

Note: The list of MPANs / MSIDs provided may be incomplete; the DNO reserves the right to apply the listed charges to any other MPANs / MSIDs associated with the site.

Annex 2 - Schedule of Charges for use of the Distribution System by Designated EHV Properties (including LDNOs with Designated EHV Properties/end-users).

Import Unique Identifier	LLFC/DUoS Tariff Id	Import MPANs/MSIDs	Export Unique Identifier	LLFC/DUoS Tariff Id	Export MPANs/MSIDs	Name	Residual Charging Band	Import Super Red unit charge (p/kWh)	Import fixed charge (p/day)	Import capacity charge (p/kVA/day)	Import exceeded capacity charge (p/kVA/day)	Export Super Red unit charge (p/kWh)	Export fixed charge (p/day)	Export capacity charge (p/kVA/day)	Export exceeded capacity charge (p/kVA/day)
New Import 39	New Import 39	New Import 39	New Export 39	New Export 39	New Export 39	White House Farm		0.001	893.06	2.57	2.57	-0.936	2350.15	0.05	0.05

Note: The list of MPANs / MSIDs provided may be incomplete; the DNO reserves the right to apply the listed charges to any other MPANs / MSIDs associated with the site.

National Grid Electricity Distribution (South Wales) plc - Effective from 1 April 2027 - Final Designated EHV import charges

Import Unique Identifier	LLFC/DUoS Tariff Id	Import MPANs/MSIDs	Name	Import Super Red unit charge (p/kWh)	Import fixed charge (p/day)	Import capacity charge (p/kVA/day)	Import exceeded capacity charge (p/kVA/day)
121	121	2100041961757	Hopkins Farm 33kV PV	0.085	16.53	1.83	1.83
122	122	2100041990623	Mynydd Yr Aber WIND Feeder 2		38.27	1.17	1.17
123	123	2100042007363	Bryn Y Rhyd	0.085	42.63	0.91	0.91
124	124	2100042049902	Coed Ely Solar Farm		6.67	1.83	1.83
181	181	2100042063039	PENCOED STOR 132kV	0.001	7.73	1.52	1.52
311	311	2100041665716	Afon Llan 33kV PV		56.62	1.45	1.45
312	312	2100041707881	Hendy 66kV WF	7.866	14.71	10.68	10.68
313	313	2100041731713 2100041731722 2100041731731	Sofidel	1.870	27,849.78	4.41	4.41
419	419	2100041256896	Mynydd Y Bwllfa WF	0.003	30.21	1.22	1.22
420	420	2100041327873	Western Wood 2 Biomass		21,101.01	1.26	1.26
421	421	2100041453132	Mynydd Y Gwair WF		14.49	1.23	1.23
460	460	2100041270311	Penrhiwarwydd Farm PV	17.905	23.94	2.00	2.00
462	462	2100041272860	Little Neath PV	0.941	10.80	3.21	3.21
463	463	2100041136537	Hopllass Farm PV	0.941	5.22	3.26	3.26
464	464	2100041278152	Gelliwern Isaf PV		3.71	2.53	2.53
465	465	2100041290958	Oak Cottage PV	1.742	162.43	2.04	2.04
466	466	2100041309926	Red Court Farm PV	5.888	5.38	2.73	2.73
467	467	2100041319358	Carn Nicholas PV	0.279	18.46	1.37	1.37
468	468	2100041320646	Brynwhilach Farm PV		70.79	1.21	1.21
469	469	2100041320682	Pant Y Moch PV1	1.842	7.32	2.68	2.68
470	470	2100041321808	Jesus College PV	0.154	4.99	3.53	3.53
471	471	2100041322183	Sully Moors STOR	0.151	7.44	1.78	1.78
472	472	2100041330919	Hafod y Dafal PV	17.745	81.57	1.47	1.47
475	475	2100041336488	Cenin Energy Park T1 WT		7.29	1.01	1.01
476	476	2100041336716	Stormy Down PV		14.17	1.54	1.54
477	477	2100041336734	Oak Grove Farm PV	1.673	3.43	1.99	1.99
478	478	2100041329063	Llancadle Farm PV	0.044	40.86	1.62	1.62
479	479	2100041339178	Lower House Farm PV	8.180	244.90	1.93	1.93
480	480	2100041343582	Derwyn PV	0.154	9.85	1.52	1.52
481	481	2100041343936	Rosedew PV	0.045	62.79	1.77	1.77
482	482	2100041344647	Pen Rhiw Caradog PV	0.013	20.62	1.60	1.60
483	483	2100041345400	Mynydd Y Gwrhyd WF	0.074	313.09	1.05	1.05
484	484	2100041346894	Tonypandy STOR		10.65	5.53	5.53
485	485	2100041346867	Traston Road STOR	0.023	9.42	2.32	2.32
486	486	2100041347202	Maesgwyn Extension WF	0.081	28.72	1.24	1.24
487	487	2100041363418	Manor Farm PV	17.813	14.03	1.63	1.63
488	488	2100041376426	Pant Y Moch PV2	1.842	7.32	2.10	2.10

Note: The list of MPANs / MSIDs provided may be incomplete; the DNO reserves the right to apply the listed charges to any other MPANs / MSIDs associated with the site.

Annex 2a - Schedule of Import Charges for use of the Distribution System by Designated EHV Properties (including LDNOs with Designated EHV Properties/end-users).

Import Unique Identifier	LLFC/DUoS Tariff Id	Import MPANs/MSIDs	Name	Import Super Red unit charge (p/kWh)	Import fixed charge (p/day)	Import capacity charge (p/kVA/day)	Import exceeded capacity charge (p/kVA/day)
489	489	2100041355189	Rhewl Farm PV	1.678	15.69	1.31	1.31
491	491	2100041383511	Bargoed PV	0.042	2,009.35	1.82	1.82
492	492	2100041383822	Mynydd Brombil WF	1.847	162.23	1.18	1.18
493	493	2100041383840	Rassau Ind Est STOR	0.167	54.19	1.46	1.46
494	494	2100041394105	Llynfi Afan WF		2,064.88	1.23	1.23
495	495	2100041394123	Mynydd Yr Aber 66kV WF		153.07	1.06	1.06
496	496	2100041401774	Waun Y Pound 1 STOR	0.170	7.07	1.78	1.78
497	497	2100041403638	Cockett Valley PV	0.132	10.19	3.63	3.63
498	498	2100041403656	Nathenfoel PV	9.047	2.67	5.64	5.64
499	499	2100041403674	Waun Y Pound 2 STOR	0.170	8.07	1.10	1.10
500	500	2100041407767	St Peters Church WF		103.23	1.14	1.14
504	504	2100040007060 2100040007079 2100040007088 2100040007097 2100040007102 2100040007111 2100040007120 2100040007130 2100040014545 2189999999714	Corus Trostre	1.839	121,096.54	3.50	3.50
507	507	2100040067486	ABB Cornelly		52.17	1.18	1.18
508	508	2100041079038	Bettws		20.81	1.32	1.32
509	509	2100040126342	Blaen Bowi	7.943	20.39	3.59	3.59
510	510	2199989614144	Mir Steel		23,395.71	0.81	0.81
511	511	2199989271918 2199989271927 2199989271936 2199989610089	Boc Margam		122,817.71	1.93	1.93
513	513	2199989616995	Alcoa		21,874.62	1.28	1.28
514	514	2189999999928	Celsa Rod Mills	0.035	134,558.78	2.79	2.79
515	515	2199989638961 2199989638970	Puma Energy (ex Murphy Oil)	1.410	20,957.44	3.12	3.12
518	518	2189999996884 2189999996893	Interbrew Magor USKM	1.786	21,140.00	4.11	4.11
519	519	2199989611204	Mainline Pipelines	0.717	2,178.88	2.83	2.83
520	520	2189999999937	Celsa 33 11		59,567.41	2.28	2.28
522	522	2199989628537	Lafarge - Blue Circle	0.040	52,182.87	2.62	2.62
529	529	2189999997284	Inco	0.255	23,458.41	3.08	3.08
532	532	2199989640232	DCWW Nantgaredig	4.855	21,874.62	5.41	5.41

Note: The list of MPANs / MSIDs provided may be incomplete; the DNO reserves the right to apply the listed charges to any other MPANs / MSIDs associated with the site.

Annex 2a - Schedule of Import Charges for use of the Distribution System by Designated EHV Properties (including LDNOs with Designated EHV Properties/end-users).

Import Unique Identifier	LLFC/DUoS Tariff Id	Import MPANs/MSIDs	Name	Import Super Red unit charge (p/kWh)	Import fixed charge (p/day)	Import capacity charge (p/kVA/day)	Import exceeded capacity charge (p/kVA/day)
533	533	2100041701230 2100041701259 2100041701268 2199989633165 2199989633174 2199989633183	Bridgend Paper Mill	3.999	124,920.49	2.07	2.07
534	534	2189999997451 2189999997460 2189999997683	Momentive Chemicals	0.174	2,534.59	2.57	2.57
535	535	2189999998924 2189999998933 2189999998942 2199989663578	Monsanto	0.024	50,900.25	2.58	2.58
536	536	2199989353701 2199989353710	Dow Corning		51,215.79	4.78	4.78
538	538	2198765295402	DCWW Rover Way	0.035	21,122.28	3.19	3.19
539	539	2100040302060	Simms metals		3,556.42	2.19	2.19
541	541	2100040752410 2100040752420	Milford Energy	0.755	119,013.63	3.11	3.11
542	542	2100040636538 2100040653932	South Hook	1.901	153,848.55	4.08	4.08
545	545	2100040769015 2100040769033 2100040769042	Felindre		128,644.24	1.16	1.16
546	546	2100040781360 2100040781379	Timet		21,874.62	2.36	2.36
547	547	2100040495610	Blaen Cregan		6.26	9.87	9.87
548	548	2100040878007	Blaengwen Wind Farm	1.187	1,138.33	5.27	5.27
549	549	2100041471220 2199989639264	Bryn Tittli Wind Farm	7.930	29.00	10.79	10.79
571	571	2100040067538	Crymlin Burrows	0.288	2,611.59	1.61	1.61
572	572	2199989635669	Dyffryn Brodyn Wind Farm	6.070	11.27	3.20	3.20
574	574	2199989614809	Llyn Brianne	5.508	118.99	6.15	6.15
575	575	2100041079171	Maerdy	0.053	50.59	1.87	1.87
576	576	2100041416441	HIRWAUN GE 33kV GEN	0.053	2,240.07	1.10	1.10
577	577	2100040719992	Margam Biomass		8,608.79	1.13	1.13
579	579	2100040485950	Pwllfa Gwatkin	0.039	2,048.76	1.21	1.21
580	580	2199989641937	Taff Ely Wind Farm		9.26	3.68	3.68
581	581	2100040609516	Trecatti	0.041	2,216.27	1.00	1.00
582	582	2100040694060	Withyhedges Landfill	1.771	2,024.02	1.86	1.86
583	583	2198765146436	Parc Cynog	6.018	4.10	2.85	2.85
584	584	2100040841771	Parc Cynog (Pendine)	6.018	39.88	2.54	2.54

Note: The list of MPANs / MSIDs provided may be incomplete; the DNO reserves the right to apply the listed charges to any other MPANs / MSIDs associated with the site.

Annex 2a - Schedule of Import Charges for use of the Distribution System by Designated EHV Properties (including LDNOs with Designated EHV Properties/end-users).

Import Unique Identifier	LLFC/DUoS Tariff Id	Import MPANs/MSIDs	Name	Import Super Red unit charge (p/kWh)	Import fixed charge (p/day)	Import capacity charge (p/kVA/day)	Import exceeded capacity charge (p/kVA/day)
585	585	2100040960600	Maesgwyn		147.56	1.24	1.24
586	586	2100040989413	Ferndale Wind Farm		60.03	3.77	3.77
587	587	2100041090096	Pant y Wal WF		60.95	8.47	8.47
588	588	2100041063650	Mynydd Portref		25.51	3.41	3.41
589	589	2100041383878	Newton Down		14.07	1.08	1.08
590	590	2100041200253	Tiers Cross PV		17.20	2.72	2.72
593	593	2189999997503 2189999997512	Thyssenkrupp Camford Pressing	3.334	20,902.86	3.22	3.22
594	594	2189999997025 2189999997034 2189999997043	Hoover	0.924	2,534.59	1.50	1.50
610	610	2100041407749	Berthllwyd PV		7.16	2.07	2.07
612	612	2100041412093	Whitton Mawr PV	0.154	16.25	1.48	1.48
613	613	2100041412118	Barry Dock Biomass	0.156	259.88	1.64	1.64
614	614	2100041412172	North Tenement PV	3.350	60.83	3.01	3.01
615	615	2100041416423	Bryncyrnau Isaf PV	5.622	31.68	3.61	3.61
620	620	2199989611348	University Hospital of Wales	0.700	21,258.57	2.24	2.24
622	622	2199989609970	QuinetiQ	8.810	2,064.55	2.41	2.41
623	623	2100041070815 2100041071828	Western Coal	0.101	2,972.78	6.05	6.05
625	625	2100040983990	Tregaron	10.338	2,002.79	1.00	1.00
627	627	2100041072798	Waunarydd STOR	0.130	2,005.32	1.02	1.02
628	628	2100041078805	Briton Ferry BESS 33KV	1.827	705.40	1.10	1.10
629	629	2100041089700	Hirwaun BESS 33KV	0.087	1,015.69	1.10	1.10
631	631	2100041080121	Ffos Las PV	1.793	21.11	2.39	2.39
632	632	2100041080140	Pont Andrew PV	1.789	21.48	1.87	1.87
634	634	2100041495912	Beaufort Power STOR	0.123	302.08	1.10	1.10
635	635	2100041611942	Cenin Energy Park ParcStormy		2,132.21	1.01	1.01
671	671	2100041495940	Brecon Power STOR	0.111	349.25	1.18	1.18
672	672	2100041611960	Cenin Energy Park Battery		194.35	1.00	1.00
680	680	2100041526631	Bryn Blaen WF	7.930	25.67	10.70	10.70
681	681	2100041539170	Ystradffin Hydro	5.531	10.88	6.12	6.12
682	682	2100041620352	Bryn Henllys 33kV PV	0.053	2,042.94	1.92	1.92
688	688	2100041546201 2100041546674	Swansea University	0.142	28,788.93	2.96	2.96
689	689	2100041611915	Cenin Energy Park T2 WT		7.29	1.12	1.12
750	750	2100041422668	Brechfa Forest West WF		1,167.36	1.33	1.33
751	751	2100041566217 2100041566341	Pembroke Refinery		156,718.78	2.90	2.90
752	752	2100041612468	LLANWERN FM 132kV GEN		2.52	4.27	4.27
760	760	2100041324775	Pen Y Cymoedd WF Aux.	0.061	5,870.11	1.48	1.48
761	761	2100041490037	Afan Way STOR	1.816	14.13	1.94	1.94

Note: The list of MPANs / MSIDs provided may be incomplete; the DNO reserves the right to apply the listed charges to any other MPANs / MSIDs associated with the site.

Annex 2a - Schedule of Import Charges for use of the Distribution System by Designated EHV Properties (including LDNOs with Designated EHV Properties/end-users).

Import Unique Identifier	LLFC/DUoS Tariff Id	Import MPANs/MSIDs	Name	Import Super Red unit charge (p/kWh)	Import fixed charge (p/day)	Import capacity charge (p/kVA/day)	Import exceeded capacity charge (p/kVA/day)
762	762	2100041418350	Manmoel PV	17.707	92.70	1.18	1.18
763	763	2100041438659	Maesgwyn Extension PV	0.081	14.36	1.28	1.28
764	764	2100041444801	Crumlin STOR	17.568	20.87	1.54	1.54
765	765	2100041445958	Pen Bryn Oer WF	0.042	70.31	1.08	1.08
880	880	2189999997595 2189999997600	Tata Margam		118,841.91	1.84	1.84
882	882	2100041103391	Tir John BESS 33KV	0.279	645.83	1.12	1.12
883	883	2100041105593	Wear Point WF	1.480	22.53	1.15	1.15
884	884	2100041113229	West Farm PV	1.053	8.66	1.35	1.35
885	885	2100041113326	Jordanston Farm PV	0.957	4.67	4.52	4.52
886	886	2100041115787	Rudbaxton PV	1.766	15.50	3.82	3.82
888	888	2100041120350	Dowlais STOR	0.041	3,238.47	0.91	0.91
890	890	2100041142372	Trident Park Recovery	0.030	2,379.66	1.13	1.13
891	891	2100041150763	Baglan Bay PV	1.828	16.76	2.89	2.89
892	892	2100041150781	Caermelyn PV	1.913	6.89	4.78	4.78
893	893	2100041150833	Liddlestone Ridge PV	2.227	2,005.30	6.63	6.63
894	894	2100041172093	Garn Farm PV	0.155	50.32	1.14	1.14
896	896	2100041195090	Treguff Farm PV	0.045	18.62	2.24	2.24
897	897	2100041197887	Loughor Solar Park	0.045	4.74	2.64	2.64
898	898	2100041197869	Sutton Farm PV	0.154	28.30	1.53	1.53
899	899	2100041201318	Cefn Betingau PV		1.95	3.45	3.45
900	900	2100041201293	Clawdd Ddu PV	0.085	3.80	4.71	4.71
901	901	2100041212221	Pentre Solar Farm	1.789	385.96	1.97	1.97
903	903	2100041230833	Fenton Farm PV	1.741	7.46	5.03	5.03
904	904	2100041240344	Yerbeston Gate Farm PV	1.742	27.19	1.94	1.94
905	905	2100041251258	Pen Y Cae PV	0.085	9.00	2.15	2.15
906	906	2100041251276	Saron PV	0.085	25.00	2.00	2.00
907	907	2100041254969	Hendre Fawr PV	0.097	2.48	3.14	3.14
908	908	2100041257250	Hendai Farm PV	0.044	4.70	2.69	2.69
909	909	2100041258591	Cwm Cae Singrug PV	17.819	8.50	2.22	2.22
910	910	2100041252819	Brynteg Farm PV	1.776	7.03	2.68	2.68
911	911	2100041260304	Court Coleman PV	0.245	24.90	4.49	4.49
912	912	2100041260331	Llwyndu Farm PV	8.800	3.33	8.31	8.31
914	914	2100041260633	Abergelli Farm PV		125.90	1.32	1.32
915	915	2100041264080	Crug Mawr Farm PV	8.756	9.30	8.37	8.37
916	916	2100041265516	Yerbeston Chapel Hill PV	0.936	97.42	1.47	1.47
917	917	2100041265809	Aberaman Park Phase 2	0.013	46.48	1.72	1.72
918	918	2100041267912	Rhyd-y-Pandy PV		9.59	2.09	2.09
919	919	2100041268837	Haverfordwest PV	1.741	9.17	2.55	2.55
920	920	2100041269812	Blaenlliedi Farm WF	1.789	23.26	2.00	2.00
2614	2614	2614	Aberystwyth - Manweb	0.540	118,841.91	8.49	8.49
7159	7159	7159	Solutia District Energy Newport	0.023	11.08	1.57	1.57

Note: The list of MPANs / MSIDs provided may be incomplete; the DNO reserves the right to apply the listed charges to any other MPANs / MSIDs associated with the site.

Annex 2a - Schedule of Import Charges for use of the Distribution System by Designated EHV Properties (including LDNOs with Designated EHV Properties/end-users).

Import Unique Identifier	LLFC/DUoS Tariff Id	Import MPANs/MSIDs	Name	Import Super Red unit charge (p/kWh)	Import fixed charge (p/day)	Import capacity charge (p/kVA/day)	Import exceeded capacity charge (p/kVA/day)
7163	7163	7163	Aberaman Park	0.013	44.82	1.71	1.71
7328	7328	7328	Dowlais II STOR CVA	0.041	46.24	0.92	0.92
7346	7346	7346	Alcoa B STOR		41.11	1.18	1.18
7450	7450	7450	Rassau Grid Stability		11,354.29	0.90	0.90
7486	7486	7486	Llandarcy STOR	0.277	25.08	1.30	1.30
7488	7488	7488	Barry STOR	0.133	16.77	1.33	1.33
7619	7619	7619	Newport BESS (Formerly Traston Road Battery Storage)	0.023	777.13	0.94	0.94
New Import 1	New Import 1	New Import 1	Bro Tathan 33kV	0.040	119,813.66	5.88	5.88
New Import 2	New Import 2	New Import 2	Manorafon 33kV	3.993	2,513.67	5.83	5.83
New Import 3	New Import 3	New Import 3	Phoenix Wharf		152,368.41	0.91	0.91
New Import 4	New Import 4	New Import 4	Plasdwr		53,025.53	2.96	2.96
New Import 5	New Import 5	New Import 5	Vantage	0.167	147,823.68	1.88	1.88
New Import 6	New Import 6	New Import 6	Abergorki WF 33kV	0.053	47.40	1.15	1.15
New Import 7	New Import 7	New Import 7	Barry Solar Park		21.54	2.02	2.02
New Import 8	New Import 8	New Import 8	BLACKBERRY LANE 33kV	0.926	52.44	2.26	2.26
New Import 9	New Import 9	New Import 9	Bryntail Solar Park		58.42	2.22	2.22
New Import 10	New Import 10	New Import 10	Brynwell Farm	0.135	76.09	4.26	4.26
New Import 11	New Import 11	New Import 11	Caenewydd 132kV PV & BESS		3,583.89	1.58	1.58
New Import 12	New Import 12	New Import 12	Coedarrhydyglyn IDNO		15.63	2.05	2.05
New Import 13	New Import 13	New Import 13	Coity Road	0.245	591.90	2.10	2.10
New Import 14	New Import 14	New Import 14	Coity Walia Area		829.22	0.81	0.81
New Import 15	New Import 15	New Import 15	Craig Y Perchych Solar Park		44.98	2.63	2.63
New Import 16	New Import 16	New Import 16	Cwm Ifor 33kV PV	0.003	3.45	1.92	1.92
New Import 17	New Import 17	New Import 17	ENVIROPARKS 33kV GEN	0.087	352.05	1.22	1.22
New Import 18	New Import 18	New Import 18	Fonmon Solar Farm	0.044	8.46	2.02	2.02
New Import 19	New Import 19	New Import 19	GCRE		120,712.66	3.45	3.45
New Import 20	New Import 20	New Import 20	Great House Farm	0.014	15.07	3.78	3.78
New Import 21	New Import 21	New Import 21	Carmel Road Solar PV (Formerly Gwenlais Solar Farm)		4.20	3.65	3.65
New Import 22	New Import 22	New Import 22	Ipswich Road		4,638.20	0.88	0.88
New Import 23	New Import 23	New Import 23	Lambeeth Solar Farm IDNO		1,293.76	0.75	0.75
New Import 24	New Import 24	New Import 24	Longlands Solar Park 33kV PV		15.88	3.71	3.71
New Import 25	New Import 25	New Import 25	Maesmawr Solar Park		178.94	1.63	1.63
New Import 26	New Import 26	New Import 26	Magor Net Zero Renewables Site		121,469.15	3.44	3.44
New Import 27	New Import 27	New Import 27	Manmoel 33kV WF	0.232	27.87	1.19	1.19
New Import 28	New Import 28	New Import 28	Mynydd Carn Y Cefn	17.587	259.35	1.10	1.10
New Import 29	New Import 29	New Import 29	Mynydd Fforch-dwm 33kV WF	1.828	139.26	1.35	1.35
New Import 30	New Import 30	New Import 30	Oaklands Farm		747.65	2.89	2.89
New Import 31	New Import 31	New Import 31	Pen Onn Solar Park		3.30	1.98	1.98
New Import 32	New Import 32	New Import 32	Penllergaer Solar Park 33kV		41.85	1.89	1.89
New Import 33	New Import 33	New Import 33	Pentrebach 66kV PV	2.025	8.37	1.86	1.86
New Import 34	New Import 34	New Import 34	Point Lane PV 33kV	1.034	31.08	1.95	1.95
New Import 35	New Import 35	New Import 35	SOUTHBROOK STOR 33kV GEN	1.664	10.06	1.45	1.45

Note: The list of MPANs / MSIDs provided may be incomplete; the DNO reserves the right to apply the listed charges to any other MPANs / MSIDs associated with the site.

Annex 2a - Schedule of Import Charges for use of the Distribution System by Designated EHV Properties (including LDNOs with Designated EHV Properties/end-users).

Import Unique Identifier	LLFC/DUoS Tariff Id	Import MPANs/MSIDs	Name	Import Super Red unit charge (p/kWh)	Import fixed charge (p/day)	Import capacity charge (p/kVA/day)	Import exceeded capacity charge (p/kVA/day)
New Import 36	New Import 36	New Import 36	Tonmawr Farm PV 33kV		25.32	2.74	2.74
New Import 37	New Import 37	New Import 37	Tredwr DC Phase 1	0.031	55,910.53	3.43	3.43
New Import 38	New Import 38	New Import 38	Wauntysswg Park 33kV PV	0.234	11.31	2.27	2.27
New Import 39	New Import 39	New Import 39	White House Farm	0.001	893.06	2.57	2.57

Note: The list of MPANs / MSIDs provided may be incomplete; the DNO reserves the right to apply the listed charges to any other MPANs / MSIDs associated with the site.

National Grid Electricity Distribution (South Wales) plc - Effective from 1 April 2027 - Final Designated EHV export charges

Export Unique Identifier	LLFC/DUoS Tariff Id	Export MPANs/MSIDs	Name	Export Super Red unit charge (p/kWh)	Export fixed charge (p/day)	Export capacity charge (p/kVA/day)	Export exceeded capacity charge (p/kVA/day)
327	327	2100041961766	Hopkins Farm 33kV PV		2,200.27	0.05	0.05
328	328	2100041990632	Mynydd Yr Aber WIND Feeder 2		2,012.92	0.05	0.05
329	329	2100042007372	Bryn Y Rhyd		5,853.51	0.05	0.05
330	330	2100042050182	Coed Ely Solar Farm		680.76	0.05	0.05
432	432	2100042063386	PENCOED STOR 132kV	-0.001	3,256.42	0.05	0.05
637	637	2100041665725	Afon Llan 33kV PV		5,096.22	0.05	0.05
638	638	2100041707890	Hendy 66kV WF		1,075.12	0.05	0.05
425	425	2100041256901	Mynydd Y Bwllfa WF		1,450.19	0.05	0.05
426	426	2100041327882	Western Wood 2 Biomass	-0.008	2,325.56	0.05	0.05
427	427	2100041453141	Mynydd Y Gwair WF		2,376.69	0.05	0.05
975	975	2100041270320	Penrhiwarwydd Farm PV		1,464.97	0.05	0.05
976	976	2100041272870	Little Neath PV		1,799.67	0.05	0.05
943	943	2100041136546	Hoplass Farm PV		1,566.09	0.05	0.05
977	977	2100041278161	Gelliwern Isaf PV		741.89	0.05	0.05
978	978	2100041290967	Oak Cottage PV		12,425.90	0.05	0.05
979	979	2100041309935	Red Court Farm PV		861.41	0.05	0.05
980	980	2100041319367	Carn Nicholas PV		1,476.91	0.05	0.05
981	981	2100041320655	Brynwhilach Farm PV		1,321.92	0.05	0.05
982	982	2100041320691	Pant Y Moch PV1		1,300.26	0.05	0.05
983	983	2100041321817	Jesus College PV		848.52	0.05	0.05
984	984	2100041322192	Sully Moors STOR	-0.151	679.99	0.05	0.05
985	985	2100041330928	Hafod y Dafal PV		5,089.91	0.05	0.05
988	988	2100041336497	Cenin Energy Park T1 WT		78.71	0.05	0.05
989	989	2100041336725	Stormy Down PV		673.26	0.05	0.05
721	721	2100041336743	Oak Grove Farm PV		858.51	0.05	0.05
722	722	2100041329072	Llancadle Farm PV		796.84	0.05	0.05
723	723	2100041339187	Lower House Farm PV		10,775.56	0.05	0.05
724	724	2100041343607	Derwyn PV		787.88	0.05	0.05
725	725	2100041343945	Rosedew PV		1,649.10	0.05	0.05
726	726	2100041344656	Pen Rhiw Caradog PV		849.41	0.05	0.05
727	727	2100041345419	Mynydd Y Gwrhyd WF	-0.136	1,471.52	0.05	0.05
728	728	2100041346900	Tonypandy STOR	-6.023	1,118.67	0.05	0.05

Note: The list of MPANs / MSIDs provided may be incomplete; the DNO reserves the right to apply the listed charges to any other MPANs / MSIDs associated with the site.

Annex 2b - Schedule of Export Charges for use of the Distribution System by Designated EHV Properties (including LDNOs with Designated EHV Properties/end-users).

Export Unique Identifier	LLFC/DUoS Tariff Id	Export MPANs/MSIDs	Name	Export Super Red unit charge (p/kWh)	Export fixed charge (p/day)	Export capacity charge (p/kVA/day)	Export exceeded capacity charge (p/kVA/day)
729	729	2100041346885	Traston Road STOR	-0.023	991.49	0.05	0.05
730	730	2100041347211	Maesgwyn Extension WF		359.04	0.05	0.05
731	731	2100041363427	Manor Farm PV		1,080.23	0.05	0.05
732	732	2100041376435	Pant Y Moch PV2		1,300.26	0.05	0.05
733	733	2100041355198	Rhewl Farm PV		941.59	0.05	0.05
735	735	2100041383520	Bargoed PV		679.11	0.05	0.05
736	736	2100041383831	Mynydd Brombil WF		5,464.48	0.05	0.05
737	737	2100041383850	Rassau Ind Est STOR	-0.167	4,055.66	0.05	0.05
738	738	2100041394114	Llynfi Afan WF		6,451.63	0.05	0.05
739	739	2100041394132	Mynydd Yr Aber 66kV WF		8,051.70	0.05	0.05
740	740	2100041401792	Waun Y Pound 1 STOR	-0.170	680.36	0.05	0.05
741	741	2100041403647	Cockett Valley PV		2,079.82	0.05	0.05
742	742	2100041403665	Nathenfoel PV		1,121.05	0.05	0.05
743	743	2100041403683	Waun Y Pound 2 STOR	-0.170	679.36	0.05	0.05
744	744	2100041407776	St Peters Church WF		4,829.85	0.05	0.05
664	664	2100040067477	ABB Cornelly		1,669.42	0.05	0.05
674	674	2100041079047	Bettws		1,539.59	0.05	0.05
660	660	2100040126333	Blaen Bowi				
619	619	2100040023638 2100040023647	Interbrew Magor USKM		118.57	0.05	0.05
633	633	2198765427530	Bridgend Paper Mill		1,157.82	0.05	0.05
617	617	2100040890412 2100040890430 2100040890440 2100040890459	Monsanto		209.47	0.05	0.05
636	636	2189999997354	Dow Corning		545.00	0.05	0.05
786	786	2100041213572	DCWW Rover Way		136.30	0.05	0.05
678	678	2100040752396 2100040752401	Milford Energy	-0.755	183.99	0.05	0.05
663	663	2100040495600	Blaen Cregan				
668	668	2100040878016	Blaengwen Wind Farm		26,181.68	0.05	0.05
651	651	2100041471239 2199989632384	Bryn Titli Wind Farm		1,063.25	0.05	0.05
665	665	2100040067529	Crymlin Burrows				
652	652	2189999997390	Dyffryn Brodyn Wind Farm		676.16	0.05	0.05
653	653	2199989612769	Llyn Brianne	-15.188	7,139.34	0.05	0.05
676	676	2100041079180	Maerdy		4,047.07	0.05	0.05

Note: The list of MPANs / MSIDs provided may be incomplete; the DNO reserves the right to apply the listed charges to any other MPANs / MSIDs associated with the site.

Annex 2b - Schedule of Export Charges for use of the Distribution System by Designated EHV Properties (including LDNOs with Designated EHV Properties/end-users).

Export Unique Identifier	LLFC/DUoS Tariff Id	Export MPANs/MSIDs	Name	Export Super Red unit charge (p/kWh)	Export fixed charge (p/day)	Export capacity charge (p/kVA/day)	Export exceeded capacity charge (p/kVA/day)
773	773	2100041416450	HIRWAUN GE 33kV GEN	-0.053	1,887.27	0.05	0.05
661	661	2100040719983	Margam Biomass		8,608.79	0.05	0.05
670	670	2100040485940	Pwllfa Gwatkin				
650	650	2189999997345	Taff Ely Wind Farm		1,019.03	0.05	0.05
662	662	2100040609507	Trecatti	-0.041	1,291.44	0.05	0.05
666	666	2100040694051	Withyhedges Landfill	-3.398	885.40	0.05	0.05
659	659	2198765142992	Parc Cynog				
667	667	2100040841780	Parc Cynog (Pendine)		696.03	0.05	0.05
684	684	2100040960619	Maesgwyn		7,673.07	0.05	0.05
679	679	2100040989431	Ferndale Wind Farm		1,921.03	0.05	0.05
685	685	2100041090087	Pant y Wal WF		5,693.15	0.05	0.05
686	686	2100041063669	Mynydd Portref		1,700.92	0.05	0.05
687	687	2100041383887	Newton Down		673.36	0.05	0.05
649	649	2100041200262	Tiers Cross PV		1,755.68	0.05	0.05
745	745	2100041407758	Berthllwyd PV		1,218.35	0.05	0.05
747	747	2100041412109	Whitton Mawr PV		714.81	0.05	0.05
748	748	2100041412127	Barry Dock Biomass	-0.156	2,970.49	0.05	0.05
749	749	2100041412181	North Tenement PV		2,767.64	0.05	0.05
772	772	2100041416432	Bryncyrnau Isaf PV		2,047.02	0.05	0.05
New Export 40	New Export 40	New Export 40	QuinetiQ		114.34	0.05	0.05
658	658	2199989641360	Tregaron	-10.338	176.09	0.05	0.05
646	646	2100041072803	Wauarlydd STOR	-0.130	859.27	0.05	0.05
645	645	2100041078814	Briton Ferry BESS 33KV	-1.881	730.93	0.05	0.05
644	644	2100041089685	Hirwaun BESS 33KV	-0.087	1,052.45	0.05	0.05
643	643	2100041080130	Ffos Las PV		1,055.45	0.05	0.05
642	642	2100041080177	Pont Andrew PV		1,073.91	0.05	0.05
922	922	2100041495921	Beaufort Power STOR	-0.123	9,919.00	0.05	0.05
695	695	2100041611951	Cenin Energy Park ParcStormy		154.51	0.05	0.05
921	921	2100041495959	Brecon Power STOR	-0.111	11,103.12	0.05	0.05
696	696	2100041611970	Cenin Energy Park Battery		194.35	0.05	0.05
990	990	2100041526640	Bryn Blaen WF		1,071.00	0.05	0.05
991	991	2100041539180	Ystradffin Hydro	-15.253	725.03	0.05	0.05
992	992	2100041620361	Bryn Henllys 33kV PV		11,029.87	0.05	0.05
690	690	2100041611924	Cenin Energy Park T2 WT		204.07	0.05	0.05
779	779	2100041422677	Brechfa Forest West WF		141,250.48	0.05	0.05
428	428	2100041612477	LLANWERN FM 132kV GEN		1,517.88	0.05	0.05
789	789	2100041490046	Afan Way STOR	-1.816	1,130.15	0.05	0.05

Note: The list of MPANs / MSIDs provided may be incomplete; the DNO reserves the right to apply the listed charges to any other MPANs / MSIDs associated with the site.

Annex 2b - Schedule of Export Charges for use of the Distribution System by Designated EHV Properties (including LDNOs with Designated EHV Properties/end-users).

Export Unique Identifier	LLFC/DUoS Tariff Id	Export MPANs/MSIDs	Name	Export Super Red unit charge (p/kWh)	Export fixed charge (p/day)	Export capacity charge (p/kVA/day)	Export exceeded capacity charge (p/kVA/day)
774	774	2100041418360	Manmoel PV		3,214.06	0.05	0.05
775	775	2100041438668	Maesgwyn Extension PV		396.81	0.05	0.05
776	776	2100041444810	Crumlin STOR	-17.568	1,255.50	0.05	0.05
777	777	2100041445967	Pen Bryn Oer WF		2,221.83	0.05	0.05
601	601	2189999998739	Tata Margam			0.05	0.05
790	790	2100041103407	Tir John BESS 33KV	-0.306	730.71	0.05	0.05
940	940	2100041105609	Wear Point WF		3,218.49	0.05	0.05
791	791	2100041113247	West Farm PV		766.03	0.05	0.05
792	792	2100041113335	Jordanston Farm PV		1,062.49	0.05	0.05
793	793	2100041115796	Rudbaxton PV		2,821.04	0.05	0.05
942	942	2100041120360	Dowlais STOR	-0.041	1,302.53	0.05	0.05
944	944	2100041142381	Trident Park Recovery	-0.031	17,525.74	0.05	0.05
945	945	2100041150772	Baglan Bay PV		4,190.79	0.05	0.05
946	946	2100041150790	Caermelyn PV		688.63	0.05	0.05
947	947	2100041150842	Liddlestone Ridge PV		896.46	0.05	0.05
948	948	2100041172109	Garn Farm PV		805.16	0.05	0.05
950	950	2100041195106	Treguff Farm PV		707.59	0.05	0.05
951	951	2100041197896	Loughor Solar Park		739.25	0.05	0.05
952	952	2100041197878	Sutton Farm PV		2,263.70	0.05	0.05
953	953	2100041201327	Cefn Betingau PV		701.64	0.05	0.05
954	954	2100041201309	Clawdd Ddu PV		1,557.82	0.05	0.05
955	955	2100041212230	Pentre Solar Farm		3,859.62	0.05	0.05
957	957	2100041230842	Fenton Farm PV		5,371.60	0.05	0.05
958	958	2100041240353	Yerbeston Gate Farm PV		2,718.86	0.05	0.05
959	959	2100041251267	Pen Y Cae PV		1,193.90	0.05	0.05
960	960	2100041251285	Saron PV		3,091.09	0.05	0.05
961	961	2100041254978	Hendre Fawr PV		843.21	0.05	0.05
962	962	2100041257269	Hendai Farm PV		782.92	0.05	0.05
963	963	2100041258607	Cwm Cae Singrug PV		850.21	0.05	0.05
964	964	2100041252837	Brynteg Farm PV		754.73	0.05	0.05
965	965	2100041260313	Court Coleman PV		7,470.03	0.05	0.05
966	966	2100041260340	Llwyndu Farm PV		726.11	0.05	0.05
968	968	2100041260642	Abergelli Farm PV		5,847.81	0.05	0.05
969	969	2100041264099	Crug Mawr Farm PV		2,232.60	0.05	0.05
970	970	2100041265525	Yerbeston Chapel Hill PV		7,793.57	0.05	0.05
971	971	2100041265818	Aberaman Park Phase 2	-0.453	3,635.39	0.05	0.05
972	972	2100041267930	Rhyd-y-Pandy PV		1,918.83	0.05	0.05

Note: The list of MPANs / MSIDs provided may be incomplete; the DNO reserves the right to apply the listed charges to any other MPANs / MSIDs associated with the site.

Annex 2b - Schedule of Export Charges for use of the Distribution System by Designated EHV Properties (including LDNOs with Designated EHV Properties/end-users).

Export Unique Identifier	LLFC/DUoS Tariff Id	Export MPANs/MSIDs	Name	Export Super Red unit charge (p/kWh)	Export fixed charge (p/day)	Export capacity charge (p/kVA/day)	Export exceeded capacity charge (p/kVA/day)
973	973	2100041268846	Haverfordwest PV		1,834.78	0.05	0.05
974	974	2100041269821	Blaenlliedi Farm WF		1,163.07	0.05	0.05
7159	7159	7159	Solutia District Energy Newport	-0.008	323.82	0.05	0.05
7163	7163	7163	Aberaman Park	-0.185	1,310.19	0.05	0.05
7329	7329	7329	Dowlais II STOR CVA	-0.041	2,540.60	0.05	0.05
7347	7347	7347	Alcoa B STOR		1,821.82	0.05	0.05
7487	7487	7487	Llandarcy STOR	-0.277	1,003.30	0.05	0.05
7489	7489	7489	Barry STOR	-0.133	670.67	0.05	0.05
7620	7620	7620	Newport BESS (Formerly Traston Road Battery Storage)	-0.023	777.17	0.05	0.05
New Export 6	New Export 6	New Export 6	Abergorki WF 33kV		4,138.17	0.05	0.05
New Export 7	New Export 7	New Export 7	Barry Solar Park		2,046.47	0.05	0.05
New Export 8	New Export 8	New Export 8	BLACKBERRY LANE 33kV		5,191.75	0.05	0.05
New Export 9	New Export 9	New Export 9	Bryntail Solar Park		7,550.99	0.05	0.05
New Export 10	New Export 10	New Export 10	Brynwell Farm		7,763.95	0.05	0.05
New Export 11	New Export 11	New Export 11	Caenewydd 132kV PV & BESS		3,772.53	0.05	0.05
New Export 12	New Export 12	New Export 12	Coedarrhydyglyn IDNO		1,514.77	0.05	0.05
New Export 13	New Export 13	New Export 13	Coity Road	-2.230	623.06	0.05	0.05
New Export 14	New Export 14	New Export 14	Coity Walia Area		58,189.20	0.05	0.05
New Export 15	New Export 15	New Export 15	Craig Y Perchych Solar Park		3,551.02	0.05	0.05
New Export 16	New Export 16	New Export 16	Cwm lfor 33kV PV		1,056.25	0.05	0.05
New Export 17	New Export 17	New Export 17	ENVIROPARKS 33kV GEN	-0.087	2,640.37	0.05	0.05
New Export 18	New Export 18	New Export 18	Fonmon Solar Farm		3,468.72	0.05	0.05
New Export 19	New Export 19	New Export 19	GCRE		756.48	0.05	0.05
New Export 20	New Export 20	New Export 20	Great House Farm		1,540.33	0.05	0.05
New Export 21	New Export 21	New Export 21	Carmel Road Solar PV (Formerly Gwenlais Solar Farm)		683.23	0.05	0.05
New Export 22	New Export 22	New Export 22	Ipswich Road		4,882.29	0.05	0.05
New Export 23	New Export 23	New Export 23	Lambeeth Solar Farm IDNO		1,361.85	0.05	0.05
New Export 24	New Export 24	New Export 24	Longlands Solar Park 33kV PV		1,539.52	0.05	0.05
New Export 25	New Export 25	New Export 25	Maesmawr Solar Park		3,844.02	0.05	0.05
New Export 27	New Export 27	New Export 27	Manmoel 33kV WF		2,598.61	0.05	0.05
New Export 28	New Export 28	New Export 28	Mynydd Carn Y Cefn		20,507.67	0.05	0.05
New Export 29	New Export 29	New Export 29	Mynydd Fforch-dwm 33kV WF		15,245.60	0.05	0.05
New Export 30	New Export 30	New Export 30	Oaklands Farm		762.75	0.05	0.05
New Export 31	New Export 31	New Export 31	Pen Onn Solar Park		1,602.10	0.05	0.05
New Export 32	New Export 32	New Export 32	Penllergaer Solar Park 33kV		4,404.86	0.05	0.05

Note: The list of MPANs / MSIDs provided may be incomplete; the DNO reserves the right to apply the listed charges to any other MPANs / MSIDs associated with the site.

Annex 2b - Schedule of Export Charges for use of the Distribution System by Designated EHV Properties (including LDNOs with Designated EHV Properties/end-users).

Export Unique Identifier	LLFC/DUoS Tariff Id	Export MPANs/MSIDs	Name	Export Super Red unit charge (p/kWh)	Export fixed charge (p/day)	Export capacity charge (p/kVA/day)	Export exceeded capacity charge (p/kVA/day)
New Export 33	New Export 33	New Export 33	Pentrebach 66kV PV		1,897.39	0.05	0.05
New Export 34	New Export 34	New Export 34	Point Lane PV 33kV		712.91	0.05	0.05
New Export 35	New Export 35	New Export 35	SOUTHBROOK STOR 33kV GEN	-1.823	2,012.83	0.05	0.05
New Export 36	New Export 36	New Export 36	Tonmawr Farm PV 33kV		7,491.55	0.05	0.05
New Export 38	New Export 38	New Export 38	Wauntysswg Park 33kV PV		11,545.23	0.05	0.05
New Export 39	New Export 39	New Export 39	White House Farm	-0.936	2,350.15	0.05	0.05

Note: The list of MPANs / MSIDs provided may be incomplete; the DNO reserves the right to apply the listed charges to any other MPANs / MSIDs associated with the site.

Annex 3 - Schedule of Charges for use of the Distribution System to Preserved/Additional LLFC Classes

We currently do not have any Preserved/Additional LLFC Classes.

National Grid Electricity Distribution (South Wales) plc - Effective from 1 April 2027 - Final LV and HV tariffs									
Supercustomer preserved charges/additional LLFCs									
	Closed LLFC/DUoS Tariff Id	PCs	Red/black unit charge p/kWh	Amber/yellow unit charge p/kWh	Green unit charge p/kWh	Fixed charge p/MPAN/day			
Notes:	[Add DNO specific notes relevant to charges]								

Site Specific preserved charges/additional LLFCs									
	Closed LLFC/DUoS Tariff Id	PCs	Red/black unit charge p/kWh	Amber/yellow unit charge p/kWh	Green unit charge p/kWh	Fixed charge p/MPAN/day	Capacity charge p/kVA/day	Exceeded capacity charge p/kVA/day	Reactive power charge p/kVAh
		0							
Notes:	Time periods [Add DNO specific notes relevant to charges] Unit charges in the red time band apply – between [xxxx] and [xxxx], Monday to Friday including bank holidays. Unit charges in the amber time band apply – between [xxxx] and [xxxx], Monday to Friday including bank holidays. Unit charges in the green time band apply – between [xxxx] and [xxxx], Monday to Friday including bank holidays, and [xxxx] and [xxxx] Saturday and Sunday. All times are UK clock-time. [Add DNO specific notes]								

Annex 4 - Charges applied to LDNOs with HV/LV end users

National Grid Electricity Distribution (South Wales) plc - Effective from 1 April 2027 - Final LDNO tariffs			
Time Bands for LV and HV Designated Properties			
Time periods	Red Time Band	Amber Time Band	Green Time Band
Monday to Friday (Including Bank Holidays) All Year	17:00 to 19:30	07:30 to 17:00 19:30 to 22:00	00:00 to 07:30 22:00 to 24:00
Saturday and Sunday All Year		12:00 to 13:00 16:00 to 21:00	00:00 to 12:00 13:00 to 16:00 21:00 to 24:00
Notes	All the above times are in UK Clock time		
Time Bands for Unmetered Properties			
	Black Time Band	Yellow Time Band	Green Time Band
Monday to Friday (Including Bank Holidays) Nov to Feb Inclusive (excluding 22nd Dec to 4th Jan inclusive)	17:00 to 19:30	07:30 to 17:00 19:30 to 22:00	00:00 to 07:30 22:00 to 24:00
Monday to Friday (Including Bank Holidays) Mar to Oct Inclusive (plus 22nd Dec to 4th Jan inclusive)		07:30 to 22:00	00:00 to 07:30 22:00 to 24:00
Saturday and Sunday All Year		12:00 to 13:00 16:00 to 21:00	00:00 to 12:00 13:00 to 16:00 21:00 to 24:00
Notes	All the above times are in UK Clock time		

Tariff name	Unique billing identifier	PCs	Red/black unit charge p/kWh	Amber/yellow unit charge p/kWh	Green unit charge p/kWh	Fixed charge p/MPAN/day	Capacity charge p/kVA/day	Exceeded capacity charge p/kVA/day	Reactive power charge p/kVArh
LDNO LV: Domestic Aggregated or CT with Residual		0, 1, 2	12.165	1.122	0.218	10.30			
LDNO LV: Domestic Aggregated (related MPAN)		2	12.165	1.122	0.218				
LDNO LV: Non-Domestic Aggregated or CT No Residual		0, 3, 4, 5-8	12.591	1.162	0.226	10.37			
LDNO LV: Non-Domestic Aggregated or CT Band 1		0, 3, 4, 5-8	12.591	1.162	0.226	14.27			
LDNO LV: Non-Domestic Aggregated or CT Band 2		0, 3, 4, 5-8	12.591	1.162	0.226	21.17			
LDNO LV: Non-Domestic Aggregated or CT Band 3		0, 3, 4, 5-8	12.591	1.162	0.226	33.10			
LDNO LV: Non-Domestic Aggregated or CT Band 4		0, 3, 4, 5-8	12.591	1.162	0.226	68.99			
LDNO LV: Non-Domestic Aggregated (related MPAN)		4	12.591	1.162	0.226				
LDNO LV: LV Site Specific No Residual		0	8.093	0.705	0.147	11.82	7.02	7.02	0.196
LDNO LV: LV Site Specific Band 1		0	8.093	0.705	0.147	113.44	7.02	7.02	0.196
LDNO LV: LV Site Specific Band 2		0	8.093	0.705	0.147	207.45	7.02	7.02	0.196
LDNO LV: LV Site Specific Band 3		0	8.093	0.705	0.147	342.01	7.02	7.02	0.196
LDNO LV: LV Site Specific Band 4		0	8.093	0.705	0.147	788.77	7.02	7.02	0.196
LDNO LV: Unmetered Supplies		0, 1 or 8	39.787	2.427	1.490				
LDNO LV: LV Generation Aggregated		0	-12.614	-1.164	-0.226	0.00			
LDNO LV: LV Generation Site Specific		0	-12.614	-1.164	-0.226	0.00			0.376
LDNO HV: Domestic Aggregated or CT with Residual		0, 1, 2	7.468	0.689	0.134	6.32			
LDNO HV: Domestic Aggregated (Related MPAN)		2	7.468	0.689	0.134				
LDNO HV: Non-Domestic Aggregated or CT No Residual		0, 3, 4, 5-8	7.729	0.713	0.139	6.37			
LDNO HV: Non-Domestic Aggregated or CT Band 1		0, 3, 4, 5-8	7.729	0.713	0.139	8.76			
LDNO HV: Non-Domestic Aggregated or CT Band 2		0, 3, 4, 5-8	7.729	0.713	0.139	13.00			
LDNO HV: Non-Domestic Aggregated or CT Band 3		0, 3, 4, 5-8	7.729	0.713	0.139	20.32			
LDNO HV: Non-Domestic Aggregated or CT Band 4		0, 3, 4, 5-8	7.729	0.713	0.139	42.35			
LDNO HV: Non-Domestic Aggregated (related MPAN)		4	7.729	0.713	0.139				
LDNO HV: LV Site Specific No Residual		0	4.968	0.433	0.091	7.25	4.31	4.31	0.120
LDNO HV: LV Site Specific Band 1		0	4.968	0.433	0.091	69.64	4.31	4.31	0.120
LDNO HV: LV Site Specific Band 2		0	4.968	0.433	0.091	127.34	4.31	4.31	0.120
LDNO HV: LV Site Specific Band 3		0	4.968	0.433	0.091	209.95	4.31	4.31	0.120
LDNO HV: LV Site Specific Band 4		0	4.968	0.433	0.091	484.20	4.31	4.31	0.120
LDNO HV: LV Sub Site Specific No Residual		0	5.246	0.385	0.100	9.21	6.58	6.58	0.119
LDNO HV: LV Sub Site Specific Band 1		0	5.246	0.385	0.100	110.74	6.58	6.58	0.119
LDNO HV: LV Sub Site Specific Band 2		0	5.246	0.385	0.100	204.65	6.58	6.58	0.119
LDNO HV: LV Sub Site Specific Band 3		0	5.246	0.385	0.100	339.08	6.58	6.58	0.119
LDNO HV: LV Sub Site Specific Band 4		0	5.246	0.385	0.100	785.40	6.58	6.58	0.119
LDNO HV: HV Site Specific No Residual		0	4.216	0.282	0.079	102.86	8.23	8.23	0.091
LDNO HV: HV Site Specific Band 1		0	4.216	0.282	0.079	973.36	8.23	8.23	0.091
LDNO HV: HV Site Specific Band 2		0	4.216	0.282	0.079	2371.02	8.23	8.23	0.091
LDNO HV: HV Site Specific Band 3		0	4.216	0.282	0.079	4344.90	8.23	8.23	0.091
LDNO HV: HV Site Specific Band 4		0	4.216	0.282	0.079	10035.52	8.23	8.23	0.091
LDNO HV: Unmetered Supplies		0, 1 or 8	24.424	1.490	0.914				
LDNO HV: LV Generation Aggregated		0	-12.614	-1.164	-0.226	0.00			
LDNO HV: LV Sub Generation Aggregated		0	-10.955	-0.978	-0.198	0.00			
LDNO HV: LV Generation Site Specific		0	-12.614	-1.164	-0.226	0.00			0.376

Note: Where a tariff only has a p/kWh unit rate in Unit Charge 1 then this unit rate applies at all times.

Annex 4 - Charges applied to LDNOs with HV/LV end users

Tariff name	Unique billing identifier	PCs	Red/black unit charge p/kWh	Amber/yellow unit charge p/kWh	Green unit charge p/kWh	Fixed charge p/MPAN/day	Capacity charge p/kVA/day	Exceeded capacity charge p/kVA/day	Reactive power charge p/kVAh
LDNO HV: LV Sub Generation Site Specific		0	-10.955	-0.978	-0.198	0.00			0.281
LDNO HV: HV Generation Site Specific		0	-6.536	-0.479	-0.124	0.00			0.239
LDNO HVplus: Domestic Aggregated or CT with Residual		0, 1, 2	4.698	0.433	0.084	3.98			
LDNO HVplus: Domestic Aggregated (related MPAN)		2	4.698	0.433	0.084				
LDNO HVplus: Non-Domestic Aggregated or CT No Residual		0, 3, 4, 5-8	4.862	0.449	0.087	4.01			
LDNO HVplus: Non-Domestic Aggregated or CT Band 1		0, 3, 4, 5-8	4.862	0.449	0.087	5.51			
LDNO HVplus: Non-Domestic Aggregated or CT Band 2		0, 3, 4, 5-8	4.862	0.449	0.087	8.18			
LDNO HVplus: Non-Domestic Aggregated or CT Band 3		0, 3, 4, 5-8	4.862	0.449	0.087	12.78			
LDNO HVplus: Non-Domestic Aggregated or CT Band 4		0, 3, 4, 5-8	4.862	0.449	0.087	26.64			
LDNO HVplus: Non-Domestic Aggregated (related MPAN)		4	4.862	0.449	0.087				
LDNO HVplus: LV Site Specific No Residual		0	3.125	0.272	0.057	4.56	2.71	2.71	0.076
LDNO HVplus: LV Site Specific Band 1		0	3.125	0.272	0.057	43.81	2.71	2.71	0.076
LDNO HVplus: LV Site Specific Band 2		0	3.125	0.272	0.057	80.11	2.71	2.71	0.076
LDNO HVplus: LV Site Specific Band 3		0	3.125	0.272	0.057	132.07	2.71	2.71	0.076
LDNO HVplus: LV Site Specific Band 4		0	3.125	0.272	0.057	304.60	2.71	2.71	0.076
LDNO HVplus: LV Sub Site Specific No Residual		0	3.215	0.236	0.061	5.65	4.03	4.03	0.073
LDNO HVplus: LV Sub Site Specific Band 1		0	3.215	0.236	0.061	67.87	4.03	4.03	0.073
LDNO HVplus: LV Sub Site Specific Band 2		0	3.215	0.236	0.061	125.43	4.03	4.03	0.073
LDNO HVplus: LV Sub Site Specific Band 3		0	3.215	0.236	0.061	207.81	4.03	4.03	0.073
LDNO HVplus: LV Sub Site Specific Band 4		0	3.215	0.236	0.061	481.35	4.03	4.03	0.073
LDNO HVplus: HV Site Specific No Residual		0	2.536	0.170	0.048	61.86	4.95	4.95	0.055
LDNO HVplus: HV Site Specific Band 1		0	2.536	0.170	0.048	585.39	4.95	4.95	0.055
LDNO HVplus: HV Site Specific Band 2		0	2.536	0.170	0.048	1425.95	4.95	4.95	0.055
LDNO HVplus: HV Site Specific Band 3		0	2.536	0.170	0.048	2613.06	4.95	4.95	0.055
LDNO HVplus: HV Site Specific Band 4		0	2.536	0.170	0.048	6035.45	4.95	4.95	0.055
LDNO HVplus: Unmetered Supplies		0, 1 or 8	15.364	0.937	0.575				
LDNO HVplus: LV Generation Aggregated		0	-4.900	-0.452	-0.088	0.00			
LDNO HVplus: LV Sub Generation Aggregated		0	-5.050	-0.451	-0.091	0.00			
LDNO HVplus: LV Generation Site Specific		0	-4.900	-0.452	-0.088	0.00			0.146
LDNO HVplus: LV Sub Generation Site Specific		0	-5.050	-0.451	-0.091	0.00			0.129
LDNO HVplus: HV Generation Site Specific		0	-6.536	-0.479	-0.124	83.99			0.239
LDNO EHV: Domestic Aggregated or CT with Residual		0, 1, 2	3.750	0.346	0.067	3.17			
LDNO EHV: Domestic Aggregated (related MPAN)		2	3.750	0.346	0.067				
LDNO EHV: Non-Domestic Aggregated or CT No Residual		0, 3, 4, 5-8	3.881	0.358	0.070	3.20			
LDNO EHV: Non-Domestic Aggregated or CT Band 1		0, 3, 4, 5-8	3.881	0.358	0.070	4.40			
LDNO EHV: Non-Domestic Aggregated or CT Band 2		0, 3, 4, 5-8	3.881	0.358	0.070	6.53			
LDNO EHV: Non-Domestic Aggregated or CT Band 3		0, 3, 4, 5-8	3.881	0.358	0.070	10.20			
LDNO EHV: Non-Domestic Aggregated or CT Band 4		0, 3, 4, 5-8	3.881	0.358	0.070	21.27			
LDNO EHV: Non-Domestic Aggregated (related MPAN)		4	3.881	0.358	0.070				
LDNO EHV: LV Site Specific No Residual		0	2.495	0.217	0.045	3.64	2.16	2.16	0.060
LDNO EHV: LV Site Specific Band 1		0	2.495	0.217	0.045	34.97	2.16	2.16	0.060
LDNO EHV: LV Site Specific Band 2		0	2.495	0.217	0.045	63.95	2.16	2.16	0.060
LDNO EHV: LV Site Specific Band 3		0	2.495	0.217	0.045	105.43	2.16	2.16	0.060
LDNO EHV: LV Site Specific Band 4		0	2.495	0.217	0.045	243.14	2.16	2.16	0.060
LDNO EHV: LV Sub Site Specific No Residual		0	2.567	0.188	0.049	4.51	3.22	3.22	0.058
LDNO EHV: LV Sub Site Specific Band 1		0	2.567	0.188	0.049	54.18	3.22	3.22	0.058
LDNO EHV: LV Sub Site Specific Band 2		0	2.567	0.188	0.049	100.12	3.22	3.22	0.058
LDNO EHV: LV Sub Site Specific Band 3		0	2.567	0.188	0.049	165.89	3.22	3.22	0.058
LDNO EHV: LV Sub Site Specific Band 4		0	2.567	0.188	0.049	384.23	3.22	3.22	0.058
LDNO EHV: HV Site Specific No Residual		0	2.024	0.136	0.038	49.38	3.95	3.95	0.044
LDNO EHV: HV Site Specific Band 1		0	2.024	0.136	0.038	467.28	3.95	3.95	0.044
LDNO EHV: HV Site Specific Band 2		0	2.024	0.136	0.038	1138.25	3.95	3.95	0.044
LDNO EHV: HV Site Specific Band 3		0	2.024	0.136	0.038	2085.85	3.95	3.95	0.044
LDNO EHV: HV Site Specific Band 4		0	2.024	0.136	0.038	4817.74	3.95	3.95	0.044
LDNO EHV: Unmetered Supplies		0, 1 or 8	12.264	0.748	0.459				
LDNO EHV: LV Generation Aggregated		0	-3.912	-0.361	-0.070	0.00			
LDNO EHV: LV Sub Generation Aggregated		0	-4.031	-0.360	-0.073	0.00			
LDNO EHV: LV Generation Site Specific		0	-3.912	-0.361	-0.070	0.00			0.116
LDNO EHV: LV Sub Generation Site Specific		0	-4.031	-0.360	-0.073	0.00			0.103

Note: Where a tariff only has a p/kWh unit rate in Unit Charge 1 then this unit rate applies at all times.

Annex 4 - Charges applied to LDNOs with HV/LV end users

Tariff name	Unique billing identifier	PCs	Red/black unit charge p/kWh	Amber/yellow unit charge p/kWh	Green unit charge p/kWh	Fixed charge p/MPAN/day	Capacity charge p/kVA/day	Exceeded capacity charge p/kVA/day	Reactive power charge p/kVAh
LDNO EHV: HV Generation Site Specific		0	-5.217	-0.382	-0.099	67.04			0.191
LDNO 132kV/EHV: Domestic Aggregated or CT with Residual		0, 1, 2	3.145	0.290	0.056	2.66			
LDNO 132kV/EHV: Domestic Aggregated (related MPAN)		2	3.145	0.290	0.056				
LDNO 132kV/EHV: Non-Domestic Aggregated or CT No Residual		0, 3, 4, 5-8	3.255	0.300	0.058	2.68			
LDNO 132kV/EHV: Non-Domestic Aggregated or CT Band 1		0, 3, 4, 5-8	3.255	0.300	0.058	3.69			
LDNO 132kV/EHV: Non-Domestic Aggregated or CT Band 2		0, 3, 4, 5-8	3.255	0.300	0.058	5.47			
LDNO 132kV/EHV: Non-Domestic Aggregated or CT Band 3		0, 3, 4, 5-8	3.255	0.300	0.058	8.56			
LDNO 132kV/EHV: Non-Domestic Aggregated or CT Band 4		0, 3, 4, 5-8	3.255	0.300	0.058	17.84			
LDNO 132kV/EHV: Non-Domestic Aggregated (related MPAN)		4	3.255	0.300	0.058				
LDNO 132kV/EHV: LV Site Specific No Residual		0	2.092	0.182	0.038	3.05	1.81	1.81	0.051
LDNO 132kV/EHV: LV Site Specific Band 1		0	2.092	0.182	0.038	29.33	1.81	1.81	0.051
LDNO 132kV/EHV: LV Site Specific Band 2		0	2.092	0.182	0.038	53.63	1.81	1.81	0.051
LDNO 132kV/EHV: LV Site Specific Band 3		0	2.092	0.182	0.038	88.42	1.81	1.81	0.051
LDNO 132kV/EHV: LV Site Specific Band 4		0	2.092	0.182	0.038	203.92	1.81	1.81	0.051
LDNO 132kV/EHV: LV Sub Site Specific No Residual		0	2.153	0.158	0.041	3.78	2.70	2.70	0.049
LDNO 132kV/EHV: LV Sub Site Specific Band 1		0	2.153	0.158	0.041	45.44	2.70	2.70	0.049
LDNO 132kV/EHV: LV Sub Site Specific Band 2		0	2.153	0.158	0.041	83.97	2.70	2.70	0.049
LDNO 132kV/EHV: LV Sub Site Specific Band 3		0	2.153	0.158	0.041	139.13	2.70	2.70	0.049
LDNO 132kV/EHV: LV Sub Site Specific Band 4		0	2.153	0.158	0.041	322.26	2.70	2.70	0.049
LDNO 132kV/EHV: HV Site Specific No Residual		0	1.698	0.114	0.032	41.41	3.32	3.32	0.037
LDNO 132kV/EHV: HV Site Specific Band 1		0	1.698	0.114	0.032	391.91	3.32	3.32	0.037
LDNO 132kV/EHV: HV Site Specific Band 2		0	1.698	0.114	0.032	954.66	3.32	3.32	0.037
LDNO 132kV/EHV: HV Site Specific Band 3		0	1.698	0.114	0.032	1749.42	3.32	3.32	0.037
LDNO 132kV/EHV: HV Site Specific Band 4		0	1.698	0.114	0.032	4040.67	3.32	3.32	0.037
LDNO 132kV/EHV: Unmetered Supplies		0, 1 or 8	10.286	0.627	0.385				
LDNO 132kV/EHV: LV Generation Aggregated		0	-3.281	-0.303	-0.059	0.00			
LDNO 132kV/EHV: LV Sub Generation Aggregated		0	-3.381	-0.302	-0.061	0.00			
LDNO 132kV/EHV: LV Generation Site Specific		0	-3.281	-0.303	-0.059	0.00			0.098
LDNO 132kV/EHV: LV Sub Generation Site Specific		0	-3.381	-0.302	-0.061	0.00			0.087
LDNO 132kV/EHV: HV Generation Site Specific		0	-4.375	-0.321	-0.083	56.23			0.160
LDNO 132kV: Domestic Aggregated or CT with Residual		0, 1, 2	1.786	0.165	0.032	1.51			
LDNO 132kV: Domestic Aggregated (related MPAN)		2	1.786	0.165	0.032				
LDNO 132kV: Non-Domestic Aggregated or CT No Residual		0, 3, 4, 5-8	1.849	0.171	0.033	1.52			
LDNO 132kV: Non-Domestic Aggregated or CT Band 1		0, 3, 4, 5-8	1.849	0.171	0.033	2.10			
LDNO 132kV: Non-Domestic Aggregated or CT Band 2		0, 3, 4, 5-8	1.849	0.171	0.033	3.11			
LDNO 132kV: Non-Domestic Aggregated or CT Band 3		0, 3, 4, 5-8	1.849	0.171	0.033	4.86			
LDNO 132kV: Non-Domestic Aggregated or CT Band 4		0, 3, 4, 5-8	1.849	0.171	0.033	10.13			
LDNO 132kV: Non-Domestic Aggregated (related MPAN)		4	1.849	0.171	0.033				
LDNO 132kV: LV Site Specific No Residual		0	1.188	0.104	0.022	1.74	1.03	1.03	0.029
LDNO 132kV: LV Site Specific Band 1		0	1.188	0.104	0.022	16.66	1.03	1.03	0.029
LDNO 132kV: LV Site Specific Band 2		0	1.188	0.104	0.022	30.46	1.03	1.03	0.029
LDNO 132kV: LV Site Specific Band 3		0	1.188	0.104	0.022	50.22	1.03	1.03	0.029
LDNO 132kV: LV Site Specific Band 4		0	1.188	0.104	0.022	115.82	1.03	1.03	0.029
LDNO 132kV: LV Sub Site Specific No Residual		0	1.223	0.090	0.023	2.15	1.53	1.53	0.028
LDNO 132kV: LV Sub Site Specific Band 1		0	1.223	0.090	0.023	25.81	1.53	1.53	0.028
LDNO 132kV: LV Sub Site Specific Band 2		0	1.223	0.090	0.023	47.69	1.53	1.53	0.028
LDNO 132kV: LV Sub Site Specific Band 3		0	1.223	0.090	0.023	79.02	1.53	1.53	0.028
LDNO 132kV: LV Sub Site Specific Band 4		0	1.223	0.090	0.023	183.03	1.53	1.53	0.028
LDNO 132kV: HV Site Specific No Residual		0	0.964	0.065	0.018	23.52	1.88	1.88	0.021
LDNO 132kV: HV Site Specific Band 1		0	0.964	0.065	0.018	222.59	1.88	1.88	0.021
LDNO 132kV: HV Site Specific Band 2		0	0.964	0.065	0.018	542.20	1.88	1.88	0.021
LDNO 132kV: HV Site Specific Band 3		0	0.964	0.065	0.018	993.59	1.88	1.88	0.021
LDNO 132kV: HV Site Specific Band 4		0	0.964	0.065	0.018	2294.92	1.88	1.88	0.021
LDNO 132kV: Unmetered Supplies		0, 1 or 8	5.842	0.356	0.219				
LDNO 132kV: LV Generation Aggregated		0	-1.863	-0.172	-0.033	0.00			
LDNO 132kV: LV Sub Generation Aggregated		0	-1.920	-0.171	-0.035	0.00			
LDNO 132kV: LV Generation Site Specific		0	-1.863	-0.172	-0.033	0.00			0.055
LDNO 132kV: LV Sub Generation Site Specific		0	-1.920	-0.171	-0.035	0.00			0.049
LDNO 132kV: HV Generation Site Specific		0	-2.485	-0.182	-0.047	31.94			0.091

Note: Where a tariff only has a p/kWh unit rate in Unit Charge 1 then this unit rate applies at all times.

Annex 4 - Charges applied to LDNOs with HV/LV end users

Tariff name	Unique billing identifier	PCs	Red/black unit charge p/kWh	Amber/yellow unit charge p/kWh	Green unit charge p/kWh	Fixed charge p/MPAN/day	Capacity charge p/kVA/day	Exceeded capacity charge p/kVA/day	Reactive power charge p/kVArh
LDNO 0000: Domestic Aggregated or CT with Residual		0, 1, 2	0.532	0.049	0.010	0.45			
LDNO 0000: Domestic Aggregated (related MPAN)		2	0.532	0.049	0.010				
LDNO 0000: Non-Domestic Aggregated or CT No Residual		0, 3, 4, 5-8	0.550	0.051	0.010	0.45			
LDNO 0000: Non-Domestic Aggregated or CT Band 1		0, 3, 4, 5-8	0.550	0.051	0.010	0.62			
LDNO 0000: Non-Domestic Aggregated or CT Band 2		0, 3, 4, 5-8	0.550	0.051	0.010	0.93			
LDNO 0000: Non-Domestic Aggregated or CT Band 3		0, 3, 4, 5-8	0.550	0.051	0.010	1.45			
LDNO 0000: Non-Domestic Aggregated or CT Band 4		0, 3, 4, 5-8	0.550	0.051	0.010	3.01			
LDNO 0000: Non-Domestic Aggregated (related MPAN)		4	0.550	0.051	0.010				
LDNO 0000: LV Site Specific No Residual		0	0.354	0.031	0.006	0.52	0.31	0.31	0.009
LDNO 0000: LV Site Specific Band 1		0	0.354	0.031	0.006	4.96	0.31	0.31	0.009
LDNO 0000: LV Site Specific Band 2		0	0.354	0.031	0.006	9.06	0.31	0.31	0.009
LDNO 0000: LV Site Specific Band 3		0	0.354	0.031	0.006	14.94	0.31	0.31	0.009
LDNO 0000: LV Site Specific Band 4		0	0.354	0.031	0.006	34.47	0.31	0.31	0.009
LDNO 0000: LV Sub Site Specific No Residual		0	0.364	0.027	0.007	0.64	0.46	0.46	0.008
LDNO 0000: LV Sub Site Specific Band 1		0	0.364	0.027	0.007	7.68	0.46	0.46	0.008
LDNO 0000: LV Sub Site Specific Band 2		0	0.364	0.027	0.007	14.19	0.46	0.46	0.008
LDNO 0000: LV Sub Site Specific Band 3		0	0.364	0.027	0.007	23.52	0.46	0.46	0.008
LDNO 0000: LV Sub Site Specific Band 4		0	0.364	0.027	0.007	54.47	0.46	0.46	0.008
LDNO 0000: HV Site Specific No Residual		0	0.287	0.019	0.005	7.00	0.56	0.56	0.006
LDNO 0000: HV Site Specific Band 1		0	0.287	0.019	0.005	66.24	0.56	0.56	0.006
LDNO 0000: HV Site Specific Band 2		0	0.287	0.019	0.005	161.35	0.56	0.56	0.006
LDNO 0000: HV Site Specific Band 3		0	0.287	0.019	0.005	295.68	0.56	0.56	0.006
LDNO 0000: HV Site Specific Band 4		0	0.287	0.019	0.005	682.95	0.56	0.56	0.006
LDNO 0000: Unmetered Supplies		0, 1 or 8	1.739	0.106	0.065				
LDNO 0000: LV Generation Aggregated		0	-0.555	-0.051	-0.010	0.00			
LDNO 0000: LV Sub Generation Aggregated		0	-0.571	-0.051	-0.010	0.00			
LDNO 0000: LV Generation Site Specific		0	-0.555	-0.051	-0.010	0.00			0.017
LDNO 0000: LV Sub Generation Site Specific		0	-0.571	-0.051	-0.010	0.00			0.015
LDNO 0000: HV Generation Site Specific		0	-0.740	-0.054	-0.014	9.50			0.027

Note: Where a tariff only has a p/kWh unit rate in Unit Charge 1 then this unit rate applies at all times.

Annex 5 - Schedule of Line Loss Factors

This table has intentionally been left blank. The line loss factors that are approved by the BSC Panel for the applicable year and consequently published on the Elexon website will take precedence and be used in Settlement. This annex will be re-published once these values are available.

National Grid Electricity Distribution (South Wales) plc - Illustrative LLFs for year beginning 1 April 2027				
Time periods	Period 1	Period 2	Period 3	Period 4
	(Name 1)	(Name 2)	(Name 3)	(Name 4)
Monday to Friday Mar to Oct			00:30 - 07:30	00:00 - 00:30 07:30 - 24:00
Monday to Friday Nov to Feb	16:00 – 19:00	07:30 – 16:00	00:30 - 07:30	00:00 - 00:30 19:00 - 24:00
Saturday and Sunday All Year			00:30 - 07:30	00:00 - 00:30 07:30 - 24:00
Notes	All the above times are in UK Clock time			

Generic demand and generation LLFs					
Metered voltage, respective periods and associated LLFCs					
Metered voltage	Period 1	Period 2	Period 3	Period 4	Associated LLFC
132kV connected					
132/EHV connected					
132/HV connected					
EHV connected					
High Voltage Substation					
High Voltage Network					
Low Voltage Substation					
Low Voltage Network					

EHV site specific LLFs					
Demand					
Site	Period 1	Period 2	Period 3	Period 4	Associated LLFC
Site 1					
Site 2					
Site 3					
Site 4					
Site 5					

EHV site specific LLFs					
Generation					
Site	Period 1	Period 2	Period 3	Period 4	Associated LLFC
Site 1					
Site 2					
Site 3					
Site 4					
Site 5					

Annex 6 - New Designated EHV Properties. Addendum to Schedule of Charges for use of the Distribution System by Designated EHV Properties (including LDNOs with Designated EHV Properties/end-users).

Annex 6 - Charges for New or Amended Designated EHV Properties

National Grid Electricity Distribution (South Wales) plc - Effective from 1 April 2027 - Final new designated EHV charges

Effective from date	Import Unique Identifier	LLFC/ DUoS Tariff Id	Import MPANs/MSIDs	Export Unique Identifier	LLFC/ DUoS Tariff Id	Export MPANs/MSIDs	Name	Residual Charging Band	Import Super Red unit charge (p/kWh)	Import fixed charge (p/day)	Import capacity charge (p/kVA/day)	Import exceeded capacity charge (p/kVA/day)	Export Super Red unit charge (p/kWh)	Export fixed charge (p/day)	Export capacity charge (p/kVA/day)	Export exceeded capacity charge (p/kVA/day)
	EDCM import 1			EDCM export 1												
	EDCM import 2			EDCM export 2												
	EDCM import 3			EDCM export 3												
	EDCM import 4			EDCM export 4												
	EDCM import 5			EDCM export 5												
	EDCM import 6			EDCM export 6												
	EDCM import 7			EDCM export 7												
	EDCM import 8			EDCM export 8												
	EDCM import 9			EDCM export 9												
	EDCM import 10			EDCM export 10												

National Grid Electricity Distribution (South Wales) plc - Effective from 1 April 2027 - Final new designated EHV line loss factors

Effective from date	Import Unique Identifier	LLFC/ DUoS Tariff Id	Import MPANs/MSIDs	Export Unique Identifier	LLFC/ DUoS Tariff Id	Export MPANs/MSIDs	Name	Residual Charging Band	Import LLF period 1	Import LLF period 2	Import LLF period 3	Import LLF period 4	Export LLF period 1	Export LLF period 2	Export LLF period 3	Export LLF period 4
	EDCM import 1			EDCM Export 1												
	EDCM import 2			EDCM Export 2												
	EDCM import 3			EDCM Export 3												
	EDCM import 4			EDCM Export 4												
	EDCM import 5			EDCM Export 5												
	EDCM import 6			EDCM Export 6												
	EDCM import 7			EDCM Export 7												
	EDCM import 8			EDCM Export 8												
	EDCM import 9			EDCM Export 9												
	EDCM import 10			EDCM Export 10												

Note: The list of MPANs / MSIDs provided may be incomplete; the DNO reserves the right to apply the listed charges to any other MPANs / MSIDs associated with the site.

Annex 7 - Schedule of Charges to recover Excess Supplier of Last Resort pass-through costs

National Grid Electricity Distribution (South Wales) plc - Effective from 1 April 2027 - Final Supplier of Last Resort and Eligible Bad Debt Pass-Through Costs

Tariff name	Open LLFCs / LDNO unique billing identifier / DUoS Tariff Id	PCs	Supplier of Last Resort Fixed charge adder* p/MPAN/day	Eligible Bad Debt Fixed charge adder*** p/MPAN/day
Domestic Aggregated or CT with Residual	100,105,800,860,101,106,801,861,116,D01	0, 1, 2	0.00	0.00
Non-Domestic Aggregated or CT No Residual	N10,N20,N30,M10,B10,X10,X20,X30,Y10,Z10	0, 3, 4, 5-8		0.00
Non-Domestic Aggregated or CT Band 1	1,2,3,117,200,201,810,811,862,863,X11,X21,X31,Y11,Z11	0, 3, 4, 5-8		0.00
Non-Domestic Aggregated or CT Band 2	N12,N22,N32,M12,B12,X12,X22,X32,Y12,Z12	0, 3, 4, 5-8		0.00
Non-Domestic Aggregated or CT Band 3	N13,N23,N33,M13,B13,X13,X23,X33,Y13,Z13	0, 3, 4, 5-8		0.00
Non-Domestic Aggregated or CT Band 4	N14,N24,N34,M14,B14,X14,X24,X34,Y14,Z14	0, 3, 4, 5-8		0.00
LV Site Specific No Residual	L00, LST	0		0.00
LV Site Specific Band 1	300	0		0.00
LV Site Specific Band 2	L02	0		0.00
LV Site Specific Band 3	L03	0		0.00
LV Site Specific Band 4	L04	0		0.00
LV Sub Site Specific No Residual	S00, SST	0		0.00
LV Sub Site Specific Band 1	344	0		0.00
LV Sub Site Specific Band 2	S02	0		0.00
LV Sub Site Specific Band 3	S03	0		0.00
LV Sub Site Specific Band 4	S04	0		0.00
HV Site Specific No Residual	H00, HST	0		0.00
HV Site Specific Band 1	400	0		0.00
HV Site Specific Band 2	H02	0		0.00
HV Site Specific Band 3	H03	0		0.00
HV Site Specific Band 4	H04	0		0.00
LDNO LV: Domestic Aggregated or CT with Residual	0	0, 1, 2	0.00	0.00
LDNO LV: Non-Domestic Aggregated or CT No Residual	0	0, 3, 4, 5-8		0.00
LDNO LV: Non-Domestic Aggregated or CT Band 1	0	0, 3, 4, 5-8		0.00
LDNO LV: Non-Domestic Aggregated or CT Band 2	0	0, 3, 4, 5-8		0.00
LDNO LV: Non-Domestic Aggregated or CT Band 3	0	0, 3, 4, 5-8		0.00
LDNO LV: Non-Domestic Aggregated or CT Band 4	0	0, 3, 4, 5-8		0.00
LDNO LV: LV Site Specific No Residual	0	0		0.00
LDNO LV: LV Site Specific Band 1	0	0		0.00
LDNO LV: LV Site Specific Band 2	0	0		0.00

Annex 7 - Schedule of Charges to recover Excess Supplier of Last Resort pass-through costs

Tariff name	Open LLFCs / LDNO unique billing identifier / DUoS Tariff Id	PCs	Supplier of Last Resort Fixed charge adder* p/MPAN/day	Eligible Bad Debt Fixed charge adder*** p/MPAN/day
LDNO LV: LV Site Specific Band 3	0	0		0.00
LDNO LV: LV Site Specific Band 4	0	0		0.00
LDNO HV: Domestic Aggregated or CT with Residual	0	0, 1, 2	0.00	0.00
LDNO HV: Non-Domestic Aggregated or CT No Residual	0	0, 3, 4, 5-8		0.00
LDNO HV: Non-Domestic Aggregated or CT Band 1	0	0, 3, 4, 5-8		0.00
LDNO HV: Non-Domestic Aggregated or CT Band 2	0	0, 3, 4, 5-8		0.00
LDNO HV: Non-Domestic Aggregated or CT Band 3	0	0, 3, 4, 5-8		0.00
LDNO HV: Non-Domestic Aggregated or CT Band 4	0	0, 3, 4, 5-8		0.00
LDNO HV: LV Site Specific No Residual	0	0		0.00
LDNO HV: LV Site Specific Band 1	0	0		0.00
LDNO HV: LV Site Specific Band 2	0	0		0.00
LDNO HV: LV Site Specific Band 3	0	0		0.00
LDNO HV: LV Site Specific Band 4	0	0		0.00
LDNO HV: LV Sub Site Specific No Residual	0	0		0.00
LDNO HV: LV Sub Site Specific Band 1	0	0		0.00
LDNO HV: LV Sub Site Specific Band 2	0	0		0.00
LDNO HV: LV Sub Site Specific Band 3	0	0		0.00
LDNO HV: LV Sub Site Specific Band 4	0	0		0.00
LDNO HV: HV Site Specific No Residual	0	0		0.00
LDNO HV: HV Site Specific Band 1	0	0		0.00
LDNO HV: HV Site Specific Band 2	0	0		0.00
LDNO HV: HV Site Specific Band 3	0	0		0.00
LDNO HV: HV Site Specific Band 4	0	0		0.00
LDNO HVplus: Domestic Aggregated or CT with Residual	0	0, 1, 2	0.00	0.00
LDNO HVplus: Non-Domestic Aggregated or CT No Residual	0	0, 3, 4, 5-8		0.00
LDNO HVplus: Non-Domestic Aggregated or CT Band 1	0	0, 3, 4, 5-8		0.00
LDNO HVplus: Non-Domestic Aggregated or CT Band 2	0	0, 3, 4, 5-8		0.00
LDNO HVplus: Non-Domestic Aggregated or CT Band 3	0	0, 3, 4, 5-8		0.00
LDNO HVplus: Non-Domestic Aggregated or CT Band 4	0	0, 3, 4, 5-8		0.00
LDNO HVplus: LV Site Specific No Residual	0	0		0.00
LDNO HVplus: LV Site Specific Band 1	0	0		0.00
LDNO HVplus: LV Site Specific Band 2	0	0		0.00
LDNO HVplus: LV Site Specific Band 3	0	0		0.00

Annex 7 - Schedule of Charges to recover Excess Supplier of Last Resort pass-through costs

Tariff name	Open LLFCs / LDNO unique billing identifier / DUoS Tariff Id	PCs	Supplier of Last Resort Fixed charge adder* p/MPAN/day	Eligible Bad Debt Fixed charge adder*** p/MPAN/day
LDNO HVplus: LV Site Specific Band 4	0	0		0.00
LDNO HVplus: LV Sub Site Specific No Residual	0	0		0.00
LDNO HVplus: LV Sub Site Specific Band 1	0	0		0.00
LDNO HVplus: LV Sub Site Specific Band 2	0	0		0.00
LDNO HVplus: LV Sub Site Specific Band 3	0	0		0.00
LDNO HVplus: LV Sub Site Specific Band 4	0	0		0.00
LDNO HVplus: HV Site Specific No Residual	0	0		0.00
LDNO HVplus: HV Site Specific Band 1	0	0		0.00
LDNO HVplus: HV Site Specific Band 2	0	0		0.00
LDNO HVplus: HV Site Specific Band 3	0	0		0.00
LDNO HVplus: HV Site Specific Band 4	0	0		0.00
LDNO EHV: Domestic Aggregated or CT with Residual	0	0, 1, 2	0.00	0.00
LDNO EHV: Non-Domestic Aggregated or CT No Residual	0	0, 3, 4, 5-8		0.00
LDNO EHV: Non-Domestic Aggregated or CT Band 1	0	0, 3, 4, 5-8		0.00
LDNO EHV: Non-Domestic Aggregated or CT Band 2	0	0, 3, 4, 5-8		0.00
LDNO EHV: Non-Domestic Aggregated or CT Band 3	0	0, 3, 4, 5-8		0.00
LDNO EHV: Non-Domestic Aggregated or CT Band 4	0	0, 3, 4, 5-8		0.00
LDNO EHV: LV Site Specific No Residual	0	0		0.00
LDNO EHV: LV Site Specific Band 1	0	0		0.00
LDNO EHV: LV Site Specific Band 2	0	0		0.00
LDNO EHV: LV Site Specific Band 3	0	0		0.00
LDNO EHV: LV Site Specific Band 4	0	0		0.00
LDNO EHV: LV Sub Site Specific No Residual	0	0		0.00
LDNO EHV: LV Sub Site Specific Band 1	0	0		0.00
LDNO EHV: LV Sub Site Specific Band 2	0	0		0.00
LDNO EHV: LV Sub Site Specific Band 3	0	0		0.00
LDNO EHV: LV Sub Site Specific Band 4	0	0		0.00
LDNO EHV: HV Site Specific No Residual	0	0		0.00
LDNO EHV: HV Site Specific Band 1	0	0		0.00
LDNO EHV: HV Site Specific Band 2	0	0		0.00
LDNO EHV: HV Site Specific Band 3	0	0		0.00
LDNO EHV: HV Site Specific Band 4	0	0		0.00
LDNO 132kV/EHV: Domestic Aggregated or CT with Residual	0	0, 1, 2	0.00	0.00

Annex 7 - Schedule of Charges to recover Excess Supplier of Last Resort pass-through costs

Tariff name	Open LLFCs / LDNO unique billing identifier / DUoS Tariff Id	PCs	Supplier of Last Resort Fixed charge adder* p/MPAN/day	Eligible Bad Debt Fixed charge adder*** p/MPAN/day
LDNO 132kV/EHV: Non-Domestic Aggregated or CT No Residual	0	0, 3, 4, 5-8		0.00
LDNO 132kV/EHV: Non-Domestic Aggregated or CT Band 1	0	0, 3, 4, 5-8		0.00
LDNO 132kV/EHV: Non-Domestic Aggregated or CT Band 2	0	0, 3, 4, 5-8		0.00
LDNO 132kV/EHV: Non-Domestic Aggregated or CT Band 3	0	0, 3, 4, 5-8		0.00
LDNO 132kV/EHV: Non-Domestic Aggregated or CT Band 4	0	0, 3, 4, 5-8		0.00
LDNO 132kV/EHV: LV Site Specific No Residual	0	0		0.00
LDNO 132kV/EHV: LV Site Specific Band 1	0	0		0.00
LDNO 132kV/EHV: LV Site Specific Band 2	0	0		0.00
LDNO 132kV/EHV: LV Site Specific Band 3	0	0		0.00
LDNO 132kV/EHV: LV Site Specific Band 4	0	0		0.00
LDNO 132kV/EHV: LV Sub Site Specific No Residual	0	0		0.00
LDNO 132kV/EHV: LV Sub Site Specific Band 1	0	0		0.00
LDNO 132kV/EHV: LV Sub Site Specific Band 2	0	0		0.00
LDNO 132kV/EHV: LV Sub Site Specific Band 3	0	0		0.00
LDNO 132kV/EHV: LV Sub Site Specific Band 4	0	0		0.00
LDNO 132kV/EHV: HV Site Specific No Residual	0	0		0.00
LDNO 132kV/EHV: HV Site Specific Band 1	0	0		0.00
LDNO 132kV/EHV: HV Site Specific Band 2	0	0		0.00
LDNO 132kV/EHV: HV Site Specific Band 3	0	0		0.00
LDNO 132kV/EHV: HV Site Specific Band 4	0	0		0.00
LDNO 132kV: Domestic Aggregated or CT with Residual	0	0, 1, 2	0.00	0.00
LDNO 132kV: Non-Domestic Aggregated or CT No Residual	0	0, 3, 4, 5-8		0.00
LDNO 132kV: Non-Domestic Aggregated or CT Band 1	0	0, 3, 4, 5-8		0.00
LDNO 132kV: Non-Domestic Aggregated or CT Band 2	0	0, 3, 4, 5-8		0.00
LDNO 132kV: Non-Domestic Aggregated or CT Band 3	0	0, 3, 4, 5-8		0.00
LDNO 132kV: Non-Domestic Aggregated or CT Band 4	0	0, 3, 4, 5-8		0.00
LDNO 132kV: LV Site Specific No Residual	0	0		0.00
LDNO 132kV: LV Site Specific Band 1	0	0		0.00
LDNO 132kV: LV Site Specific Band 2	0	0		0.00
LDNO 132kV: LV Site Specific Band 3	0	0		0.00
LDNO 132kV: LV Site Specific Band 4	0	0		0.00
LDNO 132kV: LV Sub Site Specific No Residual	0	0		0.00
LDNO 132kV: LV Sub Site Specific Band 1	0	0		0.00

Annex 7 - Schedule of Charges to recover Excess Supplier of Last Resort pass-through costs

Tariff name	Open LLFCs / LDNO unique billing identifier / DUoS Tariff Id	PCs	Supplier of Last Resort Fixed charge adder* p/MPAN/day	Eligible Bad Debt Fixed charge adder*** p/MPAN/day
LDNO 132kV: LV Sub Site Specific Band 2	0	0		0.00
LDNO 132kV: LV Sub Site Specific Band 3	0	0		0.00
LDNO 132kV: LV Sub Site Specific Band 4	0	0		0.00
LDNO 132kV: HV Site Specific No Residual	0	0		0.00
LDNO 132kV: HV Site Specific Band 1	0	0		0.00
LDNO 132kV: HV Site Specific Band 2	0	0		0.00
LDNO 132kV: HV Site Specific Band 3	0	0		0.00
LDNO 132kV: HV Site Specific Band 4	0	0		0.00
LDNO 0000: Domestic Aggregated or CT with Residual	0	0, 1, 2	0.00	0.00
LDNO 0000: Non-Domestic Aggregated or CT No Residual	0	0, 3, 4, 5-8		0.00
LDNO 0000: Non-Domestic Aggregated or CT Band 1	0	0, 3, 4, 5-8		0.00
LDNO 0000: Non-Domestic Aggregated or CT Band 2	0	0, 3, 4, 5-8		0.00
LDNO 0000: Non-Domestic Aggregated or CT Band 3	0	0, 3, 4, 5-8		0.00
LDNO 0000: Non-Domestic Aggregated or CT Band 4	0	0, 3, 4, 5-8		0.00
LDNO 0000: LV Site Specific No Residual	0	0		0.00
LDNO 0000: LV Site Specific Band 1	0	0		0.00
LDNO 0000: LV Site Specific Band 2	0	0		0.00
LDNO 0000: LV Site Specific Band 3	0	0		0.00
LDNO 0000: LV Site Specific Band 4	0	0		0.00
LDNO 0000: LV Sub Site Specific No Residual	0	0		0.00
LDNO 0000: LV Sub Site Specific Band 1	0	0		0.00
LDNO 0000: LV Sub Site Specific Band 2	0	0		0.00
LDNO 0000: LV Sub Site Specific Band 3	0	0		0.00
LDNO 0000: LV Sub Site Specific Band 4	0	0		0.00
LDNO 0000: HV Site Specific No Residual	0	0		0.00
LDNO 0000: HV Site Specific Band 1	0	0		0.00
LDNO 0000: HV Site Specific Band 2	0	0		0.00
LDNO 0000: HV Site Specific Band 3	0	0		0.00
LDNO 0000: HV Site Specific Band 4	0	0		0.00

*Supplier of Last Resort pass-through costs allocated to all domestic tariffs with a fixed charge (including LDNO)

**Eligible Bad Debt pass-through costs allocated to all metered demand tariffs (including LDNO)